

XR2400F Addressable Fire Alarm Control Panel Installation Guide



238 Zone Fire Alarm Control Panel with Built-in Communicator

MODEL XR2400F
Addressable Fire Alarm Control Panel
INSTALLATION GUIDE

FCC NOTICE

This equipment generates and uses radio frequency energy and, if not installed and used properly in strict accordance with the manufacturer's instructions, may cause interference with radio and television reception. It has been type tested and found to comply with the limits for a Class B computing device in accordance with the specification in Subpart J of Part 15 of FCC Rules, which are designed to provide reasonable protection against such interference in a residential installation. If this equipment does cause interference to radio or television reception, which can be determined by turning the equipment off and on, the installer is encouraged to try to correct the interference by one or more of the following measures:

Reorient the receiving antenna

Relocate the computer with respect to the receiver

Move the computer away from the receiver

Plug the compute into a different outlet so that computer and receiver are on different branch circuits

If necessary, the installer should consult the dealer or an experienced radio/television technician for additional suggestions. The installer may find the following booklet, prepared by the Federal Communications Commission, helpful:

"How to identify and Resolve Radio-TV Interference Problems."

This booklet is available from the U.S. Government Printing Office, Washington D.C. 20402

Stock No. 004-000-00345-4

Copyright © 2000 Digital Monitoring Products, Inc.

Information furnished by DMP is believed to be accurate and reliable.

This information is subject to change without notice.

Table of Contents

Section	Page
Introduction	1
1.1 Overview	1
1.2 System Components	1
1.3 Power Specifications	1
1.4 Before you begin	1
1.5 About this guide	1
1.6 How to use this guide	1
Mounting	2
2.1 Mounting the enclosure	2
2.2 Surface mounting	2
2.3 Flush mounting	2
2.4 The Fire Command Center LCD Keyboard	2
2.5 Wiring diagram	3
AC Connection	4
3.1 Transformers and AC Power Connection	4
3.2 28 VAC Transformer	4
3.3 16.5 VAC Transformer	5
3.4 Earth ground from the XR2400F panel	5
Secondary Power Supply	5
4.1 Description	5
4.2 Battery Connection to XR2400F Command Processor panel	5
4.3 Battery Connection to the 504-24 Power Supply	5
Two 866 NAC Modules	6
5.1 Description	6
5.2 Connection	6
5.3 Bell Silence/Bell Trouble	6
5.4 Notification Appliances	7
462N LX-Bus™ Expansion Card	8
6.1 Description	8
6.2 LX-Bus™ Expansion Capability	8
6.3 Installing the 462N module	8
Telephone RJ Connector	9
7.1 Description	9
7.2 FCC registration	9
7.3 Notification	9
7.4 Ground start	9
893A Dual Phone Line Module	9
8.1 Description	9
8.2 Connection	9
8.3 Jumper Settings	10
8.4 Digital Dialer/Multiplex	10
8.5 Phone Line Monitor	10
8.6 Processor Fail Buzzer	10

504-24 Power Supply	10
9.1 Description	10
9.2 LED's	10
9.3 504-24 Condition Chart	11
9.4 504-24 UL Listings	11
9.5 24 VDC NAC Standby Battery Calculations	11
9.6 Connection	11
Interconnect Wiring Harness	12
10.1 Interconnect Harness	12
Fire Command Center	13
11.1 Description	13
11.2 Connection	13
11.3 Remote Fire Command Center	13
XR2400F Command Processor Panel	14
12.1 Description	14
12.2 Connection	14
XR2400F Product Specifications	15
13.1 Power supply	15
13.2 Communication	15
13.3 Panel zones	15
13.4 Remote Annunciator	15
13.5 LX-Bus™	15
13.6 Outputs	15
Expansion	16
14.1 Expansion zones	16
14.2 Output (relay) expansion	16
Accessory Devices	17
15.1 Wiring diagram	17
15.2 Lightning protection	17
15.3 Accessory Devices	18
15.4 Mounting keypads and zone expanders	19
15.5 Connecting serial devices	19
Battery Information	20
16.1 Battery only restart	20
16.2 Replacement period	20
16.3 Discharge/recharge	20
16.4 Battery supervision	20
16.5 Battery cutoff	20
16.6 XR2400F power requirements	20
Bell Output	22
17.1 Terminals 5 and 6	22
Keypad and Zone Expander Bus	22

18.1	Description	22
18.2	Terminal 7 - RED	22
18.3	Terminal 8 - YELLOW	22
18.4	Terminal 9 - GREEN	22
18.5	Terminal 10 - BLACK.....	22
Smoke Detector Output		22
19.1	Terminals 11 and 12	22
19.2	Current rating	22
Powered Zones for 2-Wire Smoke Detectors		23
20.1	Terminals 25-26 and 27-28	23
Protection Zones		24
21.1	Description	24
21.2	Operational parameters	24
21.3	Zone response time	24
21.4	Keyswitch arming zone	24
Dry Contact Relay Outputs		25
22.1	Description	25
22.2	Contact rating	25
22.3	Output Harness wiring	25
12 VDC Voltage Outputs 3 to 10		25
23.1	Description	25
23.2	Output Harness wiring	25
Reset Jumper J16		26
24.1	Description	26
24.2	J4 tamper connector	26
UNIVERSAL UL BURGLARY SPECIFICATIONS		27
25.1	Introduction	27
25.2	Wiring	27
25.3	Control outside of protected area	27
25.4	Police station phone numbers.....	27
25.5	Bypass reports	27
25.6	System maintenance	27
25.7	Partitions	27
25.8	UL Listed Receivers	27
UL 1023 SPECIFICATIONS		27
26.1	Bell cutoff	27
26.2	Entry delay	27
26.3	Exit delay	27
26.4	Weekly test	27
UL 1610 AND 1076 SPECIFICATIONS		28
27.1	Multiplex network capacity	28
27.2	Opening/Closing reports	28

27.3	Closing wait	28
27.4	Proprietary dialer	28
27.5	AA Network Communication	28
UL 1635 SPECIFICATIONS	29	
28.1	System trouble display	29
28.2	Digital Dialer telephone number	29
28.3	Entry delay	29
28.4	Exit delay	29
28.5	Test time	29
28.6	Closing wait	29
UL 365 AND 609 SPECIFICATIONS	29	
29.1	System trouble display	29
29.2	Grade A bell	29
29.3	Bell cutoff	29
29.4	Automatic bell test	29
29.5	Line security for Police Connect	29
29.6	High Line Security	29
UNIVERSAL UL and NFPA FIRE ALARM SPECIFICATIONS	30	
30.1	Introduction	30
30.2	Wiring	30
30.3	Transformer	30
30.4	End of Line resistor	30
30.5	System trouble display	30
30.6	Fire display	30
30.7	Police station phone number	30
30.8	System maintenance	30
30.9	Audible alarm	30
30.10	Fire zone programming	30
30.11	Style D zones	30
30.12	Video Option	30
30.13	UL Listed Receivers	30
UL 985 NFPA 72 (Chapter 2) SPECIFICATIONS	31	
31.1	Bell output definition	31
UL 864 NFPA 72 (Chapter 9) SPECIFICATIONS	31	
32.1	Zone restoral reports	31
32.2	Power fail delay	31
32.3	Sprinkler supervisory	31
32.4	DACT systems	31
32.5	Type 2 and Type 3 Central Station Service	31
32.6	Type 1 Central Station Service	31
32.7	Local Protective Signaling Systems	31
32.8	Proprietary Protective Signaling Systems	32
32.9	Remote Station Protective Signaling Systems	32

CALIFORNIA STATE FIRE MARSHAL SPECIFICATIONS	32
33.1 Bell output definition.....	32
System Wiring Diagrams	33
34.1 Multiple indicating circuit modules	33
34.2 Multiple indicating circuit modules for zoned annunciation	34
34.3 Dual Style D Zone Module installation.....	35
34.4 Remote Station reversing relay connection	36
34.5 Supervised remote relay	37
34.6 Cellular backup installation for Derived Channel burglary	38
34.7 LX-Bus™ Module Connection	39
34.8 Second LX-Bus with Auxiliary Power Supply	40
OPERATING INSTRUCTIONS	41

Introduction

1.1 Overview

The DMP XR2400F Addressable Fire Alarm Control Panel (FACP) is an expandable 24 VDC Fire Alarm Control with built-in DACT and LCD Fire Command Center keyboard with membrane keyswitch. A complete system can provide a total of 494 programmable inputs and outputs for commercial and industrial fire alarm service. The 24 VDC 4 Amp notification appliance power is distributed between two class B style W NAC outputs. Additional NAC outputs can be added with conventional supervision modules or addressable power supply/boosters. Addressable smoke detectors and input modules round out the XR2400F to deliver a truly flexible and expansive fire detection and notification system. The Fire Alarm Control Panel is shipped pre-wired in a red metal enclosure housing the necessary components to monitor and control fire alarm notification appliances.

1.2 System Components

The XR2400F FACP consists of the following components:

- One Model XR2400F Command Processor panel
- Two Model 866 Class B Style W NAC modules
- One Model 504-24 VDC Power Supply
- One 100 VAC transformer, TF-0015
- Two Model 305 Relays
- One Model 893A Dual Phone Line module
- One Model 630F PCB and membrane switch
- One 28 VAC transformer, TF-0030
- One Model 462N LX-Bus Expansion Card

1.3 Power Specifications

Command Processor:

Transformer Input of 16.5 VAC 100 VA

Standby battery of 12 VDC 30.8Ah (100VA charges up to four 7.7Ah batteries)

Auxiliary power of 12 VDC at 1 Amp

NAC Output of 12 VDC at 1.5 Amp

All circuits are inherent Power Limited except red battery wires.

NAC Output:

24 VDC 4 Amps shared between NACs 1 and 2

1.4 Before you begin

Before installing the XR2400F, we recommend you read through the entire contents of this guide. Familiarize yourself with the features of the panel and the key points to remember during the installation. Be sure to read and understand all of the caution statements printed in bold italics.

1.5 About this guide

The information in this guide is organized into five sections: Table of Contents, Introduction, Installation, Compliance, and System Wiring Diagrams.

- The Table of Contents at the front lists the headings and subheadings used throughout each section of the guide.
- The Introduction section gives you an overview of the XR2400F and this document.
- The Installation section begins with mounting instructions for the enclosure. Wiring diagrams for each component also appear in this section.
- The Compliance section lists all UL listings the XR2400F currently follows.
- The System Wiring Diagrams provide illustrations of typical XR2400F systems.

Caution notes

Throughout this guide you will see caution notes containing information you need to know when installing the XR2400F panel. These cautions are written in **bold and italics**. Failing to follow the caution note may cause damage to the equipment or improper operation of one or more components in the system.

1.6 How to use this guide

To locate information about the installation of the XR2400F, go to the Table of Contents at the front of this guide. Find the subject heading that best describes the information you need and turn to the section number shown to the right of the heading. If you cannot find the information you need under that heading, scan through a few of the headings and read the text under those that sound similar.

Mounting

2.1 Mounting the enclosure

The XR2400F must be mounted in a secure, dry location to protect the unit from damage due to tampering and the elements. The enclosure can be either flush mounted or surface mounted and includes a hinged door with lock. A hole has been cut in the enclosure door to allow access to the Fire Command Center without opening the door. Below are the mounting hole locations for the panel's enclosure.

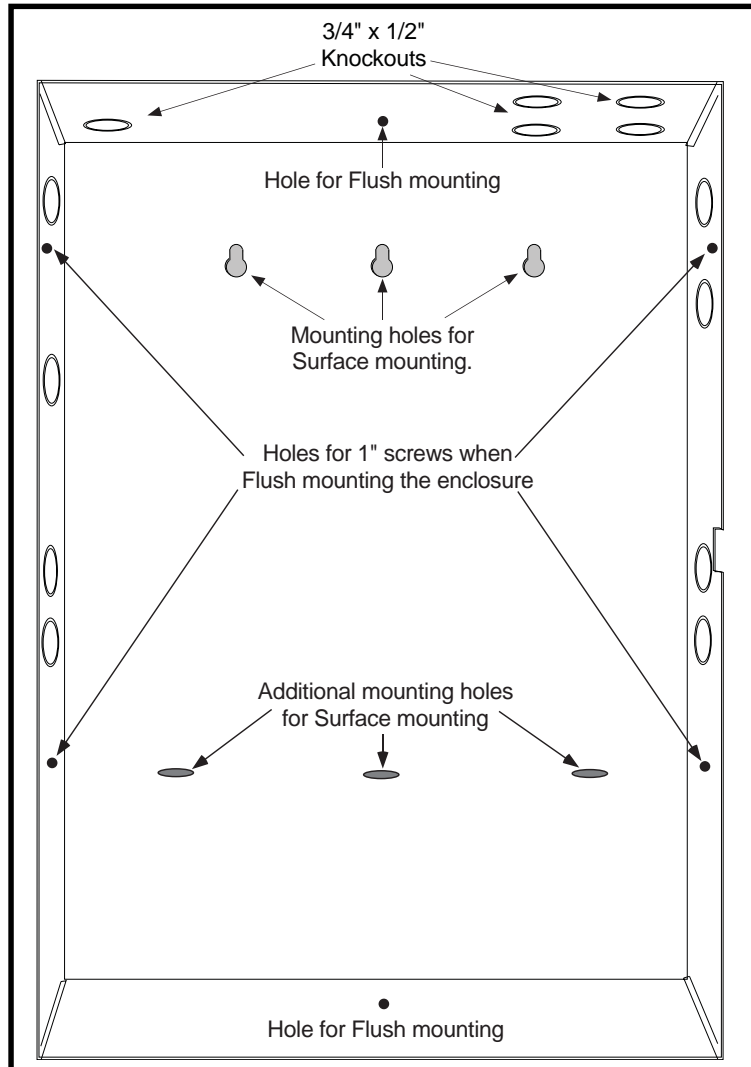

Figure 1: Enclosure Mounting Diagram

2.2 Surface mounting

The center hole of the enclosure should be attached to a stud in the wall. Due to the weight of the enclosure, especially the batteries, it is extremely important to mount the enclosure on the stud. Attach the two holes beside the center hole to sheetrock to secure enclosure. When mounting the enclosure, be sure to leave room for the panel door to swing open. The door's lock should be in an easily accessible place.

2.3 Flush mounting

The enclosure can also be flush mounted (recessed in the wall). 1" screws should be used to secure the enclosure between two studs using the two sets of holes on the sides of the enclosure.

2.4 The Fire Command Center LCD Keyboard

A Fire Command Center has been factory installed in the XR2400F panel. The keyboard is mounted on a metal backplate. A hole has been cut into the enclosure door to allow users to control the XR2400F without opening the enclosure door. Also, a keyswitch has been installed and pre-wired to the left of the keyboard. The user can turn the keyswitch to enable the four functions keys without opening the enclosure door.

2.5 Wiring diagram

The XR2400F system below shows the layout of the components. The wires shown in this guide have been factory installed and connected. The dashed lines represent wires that run underneath a component. Detailed wiring diagrams for each supplied component appear in following sections of this guide.

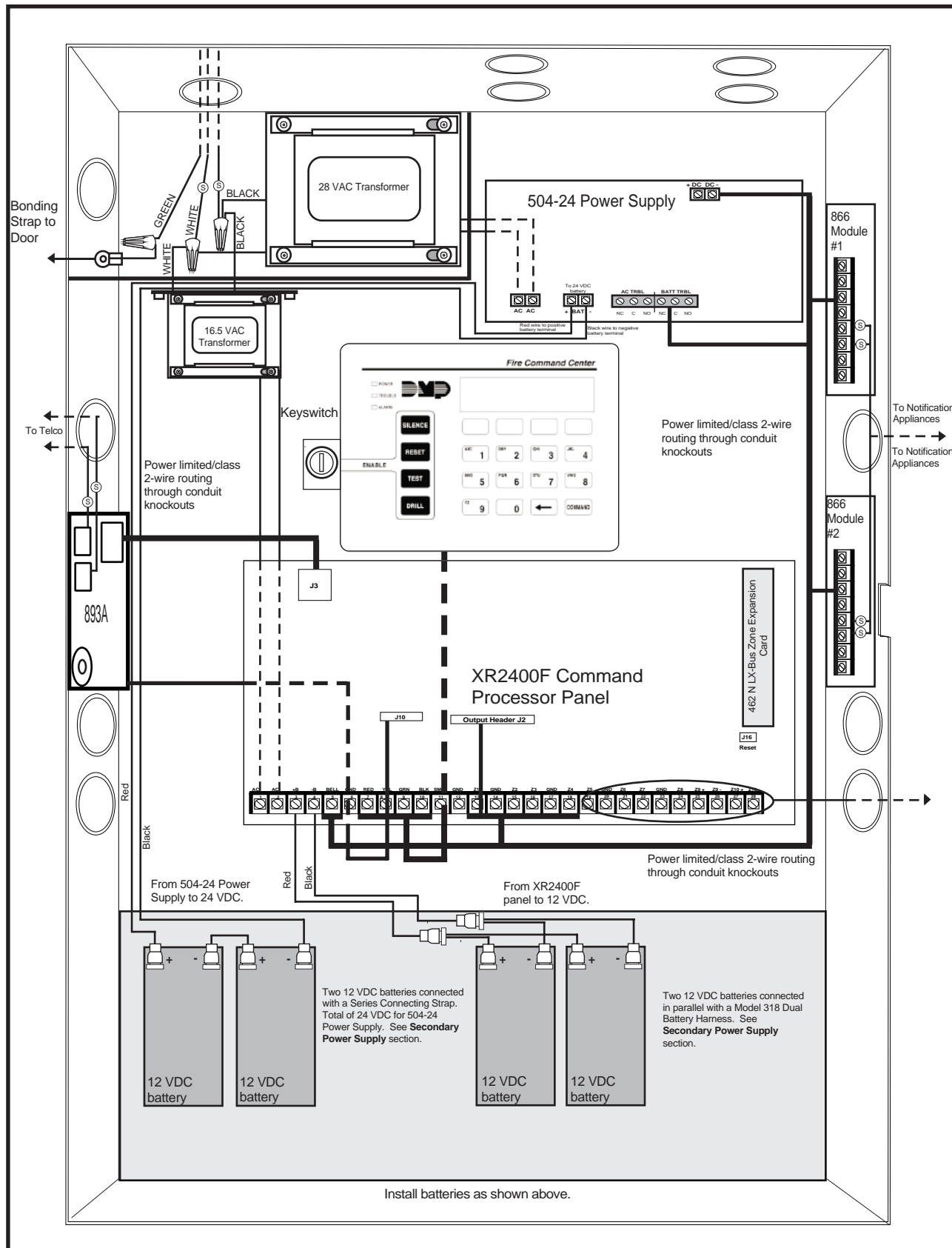

Figure 2: XR2400F System

AC Connection

3.1 Transformers and AC Power Connection

The AC connection should be completed by a licensed electrician.

Never share the Fire Alarm Control Panel circuit with any other equipment.

The XR2400F comes supplied with two transformers: the 16.5 VAC 100 VA transformer and the 28 VAC 175 VA transformer. The 28 VAC and 16.5 VAC transformers' white leads and black leads must be connected together respectively. These wires must be connected to an unswitched 120 VAC 60 Hz power source with at least 1.85 Amps of available current.

Black wire - attach the black 120 VAC wire to the black wire of the transformers.

White wire - attach the white 120 VAC wire to the white wire of the transformers.

Green wire - attach the green wire lead to the green wire attached to the enclosure.

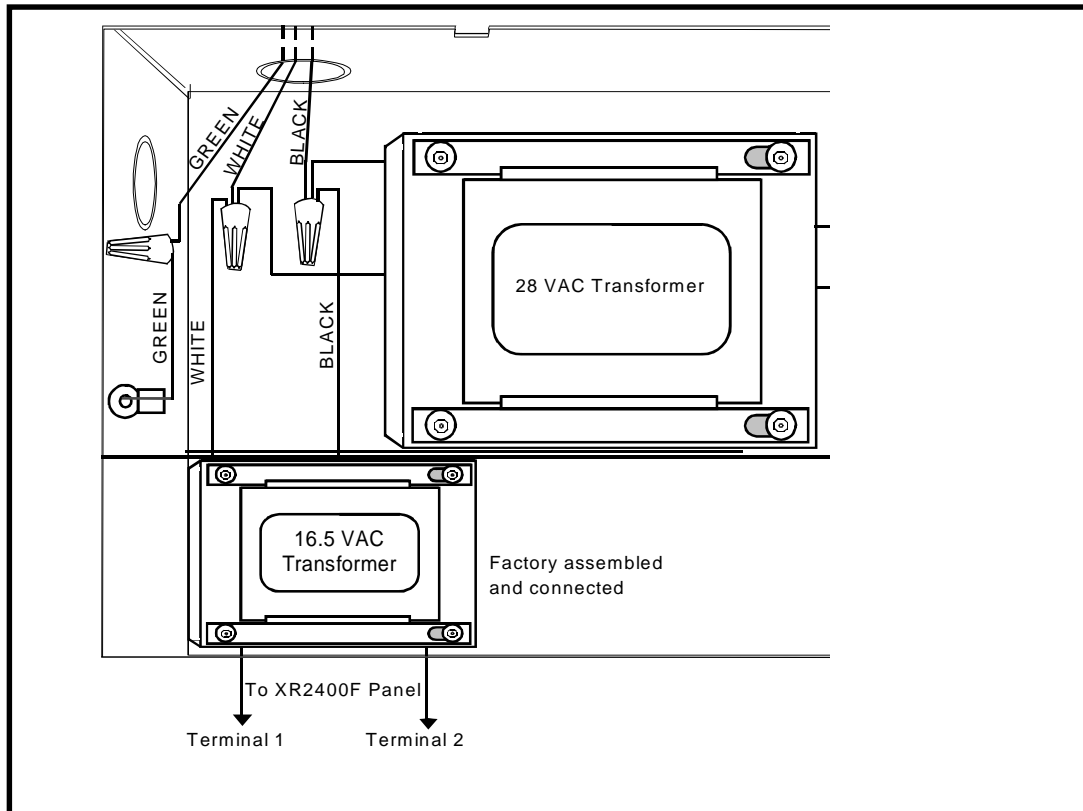

Figure 3: Transformers and AC Power Connection

Always ground the panel before applying power to any devices!

Use 18 AWG or larger for all power connections. The XR2400F must be properly grounded before connecting any devices or applying power to the panel. Proper grounding protects against Electrostatic Discharge (ESD) that can damage system components.

3.2 28 VAC Transformer

The 28 VAC Transformer supplies power to the AC terminals of the 504-24 Power Supply which is factory pre-wired to the two 866 NAC modules. The 28 VAC is located in the upper right hand corner of the enclosure surrounded by a metal divider. See Figure 3: Transformers and AC Power Connection. Also refer to **504-24 Power Supply Connection**.

3.3 16.5 VAC Transformer

The 16.5 VAC 100 VA transformer supplies power to the XR2400F panel and is factory pre-wired. See Figure 3: Transformers and AC Power Connection. Also refer to Figure 11: XR2400F Panel Wiring Diagram.

3.4 Earth ground from the XR2400F panel

Terminal 4 of the XR2400F panel must be connected to earth ground using 14 gauge or larger wire to provide proper transient suppression. DMP recommends connecting to a cold water pipe or ground rod only. Do not connect to an electrical ground or conduit, sprinkler or gas pipes, or to a telephone company ground.

Secondary Power Supply

4.1 Description

The XR2400F system includes pre-wired cables for connecting a 24 VDC battery to the 504-24 power supply and a 12 VDC battery to the XR2400F panel. For 24 VDC battery operation to the 504-24, connect two 12 VDC sealed lead-acid batteries in series using the included series connecting strap (See Figure 4). **Observe polarity when connecting all batteries.**

Use sealed lead-acid batteries only. Use the DMP Model 367, 12 VDC 7.0Ah sealed lead-acid rechargeable battery. Batteries supplied by DMP or manufactured by Eagle Picher or Yuasa have been tested to ensure proper charging with DMP products.

Gel cell batteries cannot be used with the XR2400F panel.

4.2 Battery Connection to XR2400F Command Processor panel

For 12 VDC battery operation to the XR2400F, connect the black battery lead to the negative terminal of the battery. The black battery wire is connected to terminal 4 of the XR2400F panel.

Connect the red battery lead to the positive terminal of the battery. The red battery wire is connected to terminal 3 of the XR2400F panel. See Figure 11: XR2400F Panel Wiring Diagram and Figure 2: XR2400F System.

You can add a second battery in parallel using the DMP Model 318 Dual Battery Harness. When wiring two batteries with the Model 318 Dual Battery Harness, plug the red male end of the Dual Battery Harness into the red female battery lead from the panel. Plug the black male end of the Dual Battery Harness into the black female battery lead from the panel. Attach both female leads from the Dual Wiring Harness to the two batteries as described above. See Table 3: Battery Calculations.

4.3 Battery Connection to the 504-24 Power Supply

The 504-24 is powered by 24 VDC. After connecting two 12 VDC batteries together using the series connecting strap (or after installing one 24 VDC battery) connect the black battery wire to the negative terminal of the 24 VDC battery. The black battery wire is connected to the negative AC terminal of the 504-24.

Connect the red battery wire to the positive terminal of the 24 VDC battery. The red battery wire is connected to the positive AC terminal of the 504-24.

See Figure 9: 504-24 Wiring Diagram and Figure 2: XR2400F system. Also see **Battery Information** section.

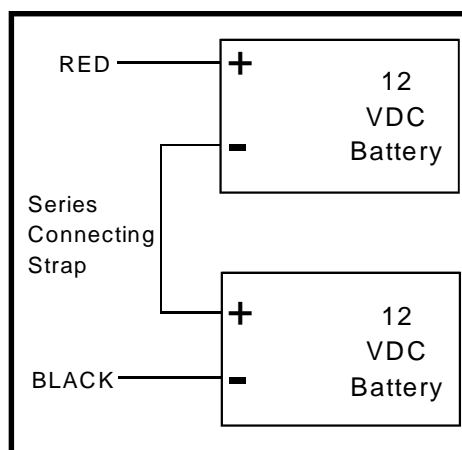

Figure 4: 24 VDC wiring

Two 866 NAC Modules

5.1 Description

Each 866 provides one style W indicating circuit for supervising UL polarized notification appliances, such as bells, strobes, and horns. See Table 1: Notification Appliances for a list of approved notification appliances.

5.2 Connection

Each 866 module is pre-installed on the right side of the enclosure wall using the standard three-hole configuration. The modules are factory pre-wired to each other, the 504-24, and the XR2400F panel. Refer to figure below and to Figure 2: XR2400F System for wiring connections.

You can connect 24 VDC Notification Appliances to terminals 5 and 6 of each module. Each module provides a zone of notification and can be activated separately.

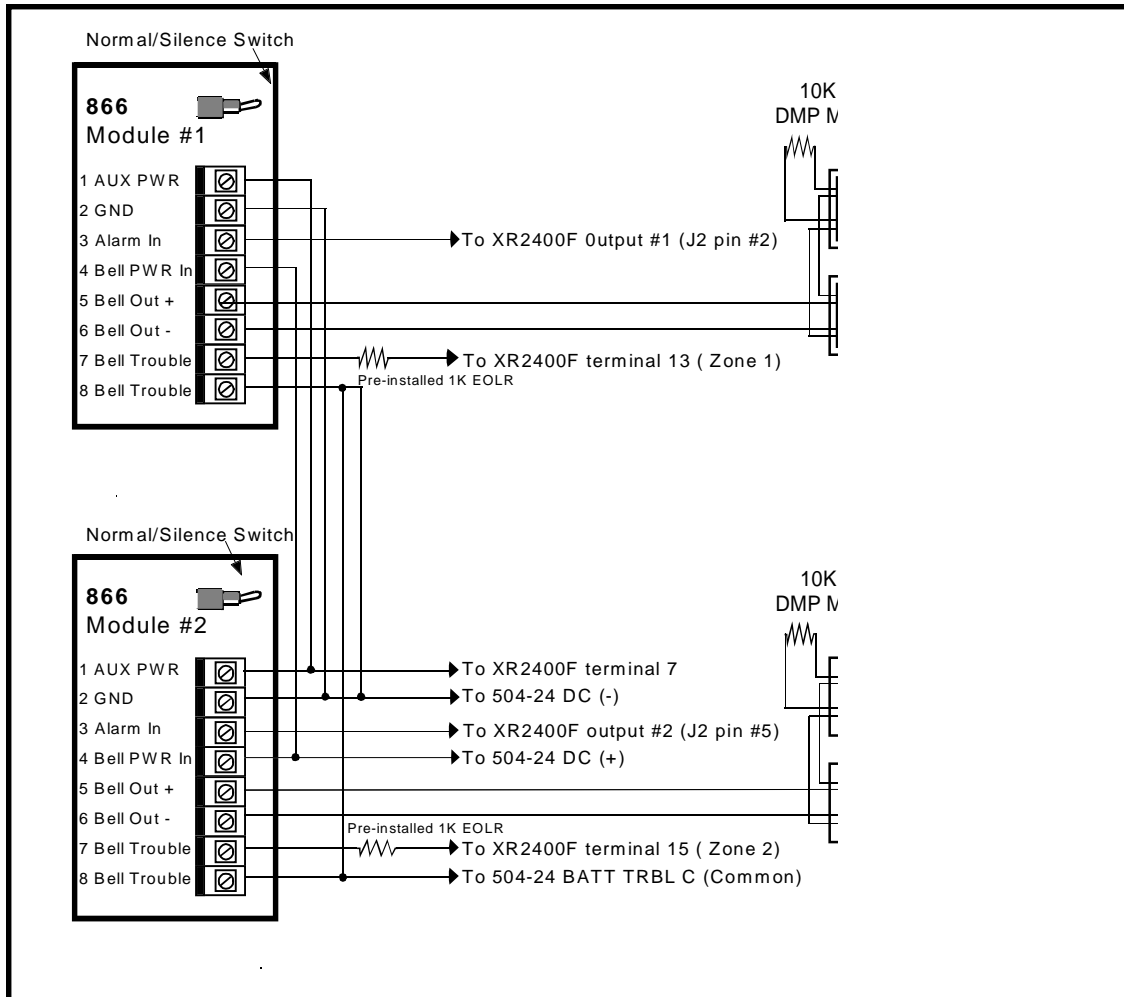

Figure 5: 866 Wiring Diagram

5.3 Bell Silence/Bell Trouble

A bell silence switch on the 866 module is provided to prevent sounding of the indicating devices when testing the system. When the **Silence** position is selected, a fifteen second delay occurs before the 866 bell trouble contacts (terminals 7 and 8) open. Select the **Normal** position after testing to return the 866 module to normal operation.

5.4 Notification Appliances

The following table indicates the approved notification appliances that can be used with the XR2400F system.

DMP Model	Description
802	Multi-tone Audible Appliance
803	Horn Appliance
831	Single Circuit Sync Module
832	Dual Circuit Sync Module
901	Piezoelectric Mini Horn
904	Horn Appliance
904WP	Horn Appliance, Weather-proof
906-6	Motor Bell 6"
906-10	Motor Bell 10"
921-MCW	Multi-candela Remote Strobe
921-15C	Remote Strobe, Ceiling Mount, 15cd
921-15W	Remote Strobe, Wall Mount, 15cd
921-30C	Remote Strobe, Ceiling Mount, 30cd
921-30W	Remote Strobe, Wall Mount, 30cd
921-75C	Remote Strobe, Ceiling Mount, 75cd
921-75W	Remote Strobe, Wall Mount, 75cd
921-100C	Remote Strobe, Ceiling Mount, 100cd
921-110W	Remote Strobe, Wall Mount, 110cd
921-1575W	Remote Strobe, Wall Mount, 15/75cd
922-MCW	Multi-candela Remote Strobe
922-15W	Remote Strobe, Retrofit Plate, 15cd
922-30W	Remote Strobe, Retrofit Plate, 30cd
922-75W	Remote Strobe, Retrofit Plate, 75cd
922-110W	Remote Strobe, Retrofit Plate, 110cd
922-1575W	Remote Strobe, Retrofit Plate, 15/75cd

DMP Model	Description
923-MCW	Multi-candela Horn/Strobe
923-15W	Horn/Strobe, Flush Mount, 15cd
923-30W	Horn/Strobe, Flush Mount, 30cd
923-75W	Horn/Strobe, Flush Mount, 75cd
923-110W	Horn/Strobe, Flush Mount, 110cd
923-1575W	Horn/Strobe, Flush Mount, 15/75cd
924-MCW	Multi-candela Audible Strobe
924-15C	Audible Strobe, Ceiling Mount, 15cd
924-15W	Audible Strobe, Wall Mount, 15cd
924-30C	Audible Strobe, Ceiling Mount, 30cd
924-30W	Audible Strobe, Wall Mount, 30cd
924-75C	Audible Strobe, Ceiling Mount, 75cd
924-75W	Audible Strobe, Wall Mount, 75cd
924-100C	Audible Strobe, Ceiling Mount, 100cd
924-110W	Audible Strobe, Wall Mount, 110cd
924-1575W	Audible Strobe, Wall Mount, 15/75cd

Table 1: Notification Appliances

462N LX-Bus™ Expansion Card

6.1 Description

The 462N LX-Bus™ Expansion Card provides an additional 100 zones to the XR2400F.

6.2 LX-Bus™ Expansion Capability

The 462N card provides a 4-wire LX-Bus™ that allows you to connect up to 100 Model 521LX or 521LXT Addressable Smoke Detectors. Also the LX-Bus™ could connect up to 25 Model 714 and 715 Zone Expanders or 716 Output Expanders, up to six Model 714-16 or 715-6 Zone Expanders, and up to 100 Model 711 and 711E Zone Expanders. Power for the devices is provided through the **Black** and **Red** wires of the expansion harness.

6.3 Installing the 462N module

1. Remove AC and battery power from the XR2400F panel before installing the 462N card.
2. Align the 50 pin connector of the 462N with the J6 connector on the XR2400F panel.
3. Press the 462N onto the J6 connector while applying even pressure to both sides.

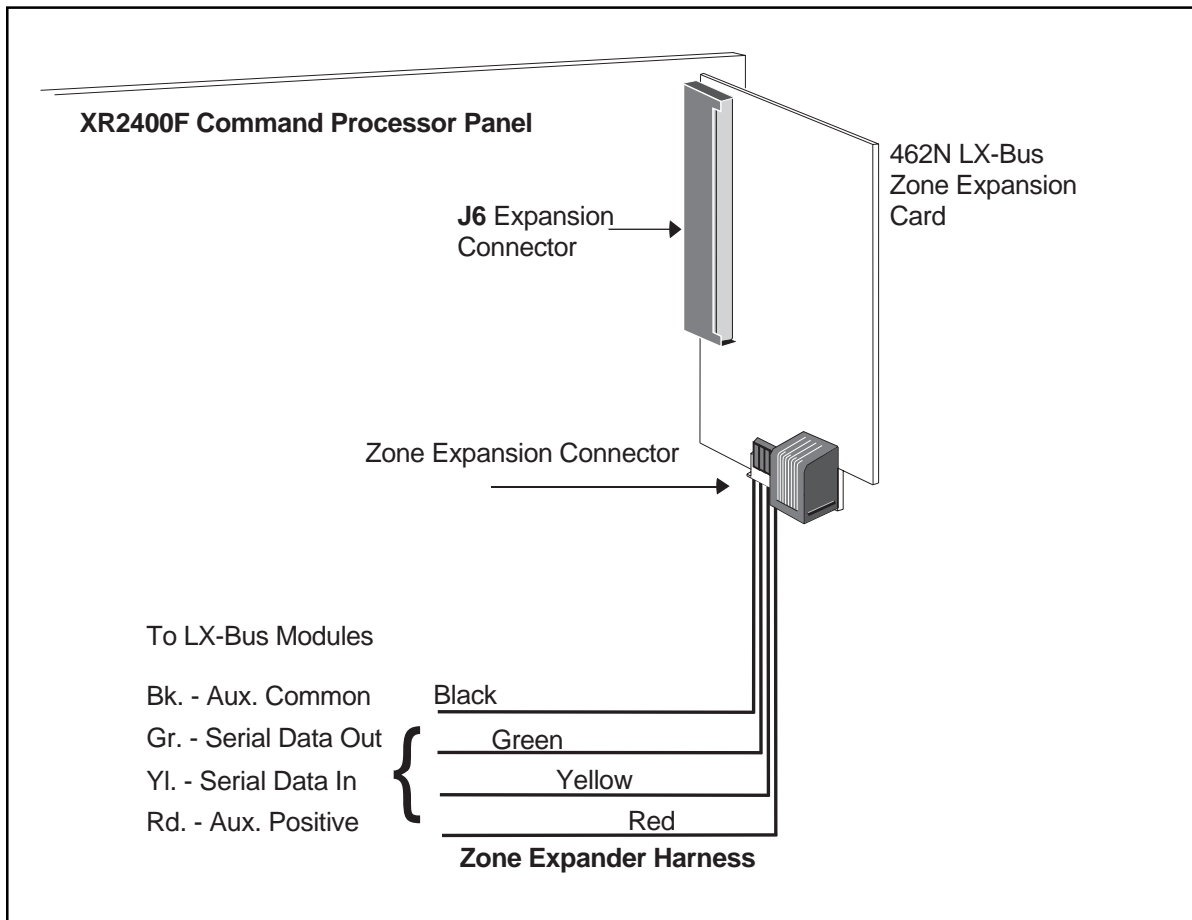

Figure 6: 462N Wiring Diagram

Telephone RJ Connector

7.1 Description

Connect the XR2400F system to two lines of the public telephone network by installing two DMP 356 RJ Cables between the RJ31X or RJ38X phone jacks and the 893's J4 connector (for main line) and J5 (for backup line). Set the 3-pin headers labeled J11 and J12 on the XR2400F to **DD** for digital dialer, Contact ID, or Modem IIe operation. See **893A Dual Phone Line Module**.

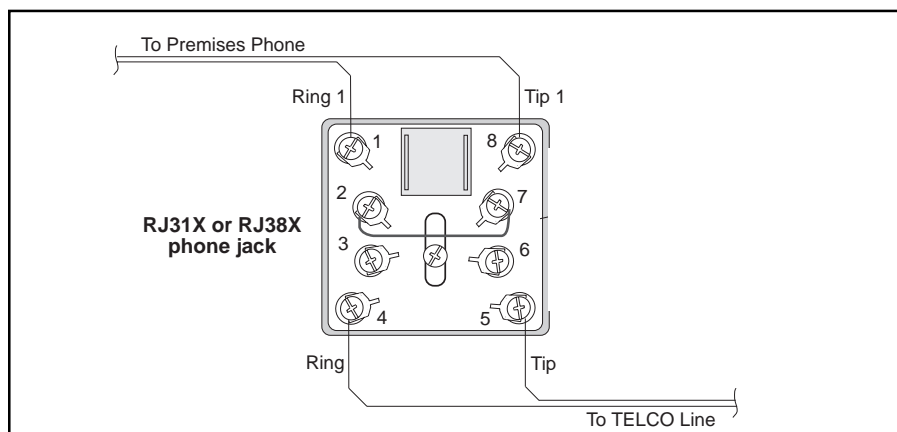

Figure 7: Phone Jack Wiring

7.2 FCC registration

The Model XR200/XR2400F complies with FCC part 68 and is registered with the FCC. Registration number: CCKUSA-18660-AL-R / Ringer Equivalence: 1.1B

7.3 Notification

Registered terminal equipment must not be repaired by the user. In case of trouble, the device must be immediately unplugged from the telephone jack. The factory warranty provides for repairs. Registered terminal equipment may not be used on party lines or in connection with coin telephones. Notification must be given to the telephone company of:

- a. The particular line(s) the service is connected to
- b. The FCC registration number
- c. The ringer equivalence
- d. The make, model, and serial number of the device

7.4 Ground start

Ground start phones cannot be used on commercial or residential fire applications.

893A Dual Phone Line Module

8.1 Description

The 893A is a dual telephone line supervision module that allows the panel to indicate a phone line failure to the premises and the central monitoring station. After the 893A senses a failure on the main line, it switches to the backup, or secondary, phone line. The 893A is installed on the left side of the XR2400F enclosure.

8.2 Connection

The 893A connects the panel to the public telephone network by installing a DMP 356 RJ Cable between the XR2400F panel's J3 connector and the 893's J3 connector labeled PANEL. The two communication jumpers must be set to either **DD** or **MPX**.

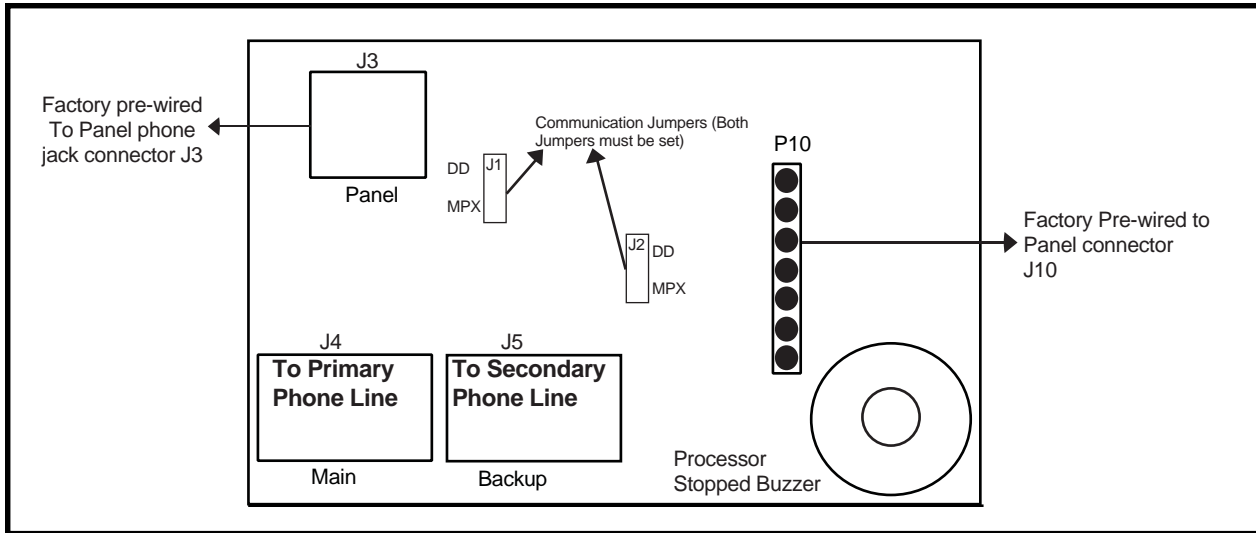

Figure 8: 893A Wiring Diagram

8.3 Jumper Settings

There are two sets of jumpers on the 893A module. When setting the module for either **DD** (digital dialer) or **MPX** (multiplex), *both* jumpers must be set.

8.4 Digital Dialer/Multiplex

You can configure the 893A to provide two lines of digital dialer or one line of multiplex with digital dialer backup. For multiplex operation both jumpers (J1 and J2) must be set to **MPX**. Also, jumpers J11 and J12 on the panel must be set to **MPX**. See **XR2400F Command Processor Panel Connection**. The XR2400F is preset at the factory for Digital Dialer. The Main modular jack (J4) is used for the primary dialer or multiplex line. The Backup modular jack (J5) is used for the secondary digital dialer line.

8.5 Phone Line Monitor

The 893A uses a phone line monitor for the main and backup phone lines. When sending a report, the 893A verifies the main phone line is working before sending. If the line is bad, the module tests the backup phone line. The 893A sends the report on the first working phone line.

The phone line monitor has a two minute trouble delay and a one minute restore delay. Phone line trouble is displayed in the Fire Command Center LCD Status List as a System Trouble. The Fire Command Center LCD is factory programmed to display system troubles in the Status List.

8.6 Processor Fail Buzzer

The 893A module also monitors the panel's CPU and sounds a trouble buzzer whenever either the panel's processor is reset using J16 or the processor stops functioning.

504-24 Power Supply

9.1 Description

The 504-24 is a power limited, switching power supply that meets UL, CSFM, NFPA, and FCC compliance standards. Model 504-24 is rated for 24 VDC @ 4 Amps maximum and supplies power to the 866 NAC modules.

9.2 LED's

The 504-24 has two status LED's that show the current state of power. The green LED indicates low AC input. The red LED indicates low standby battery power after AC has failed.

9.3 504-24 Condition Chart

Condition	504-24	LED	Status	Condition
AC Trouble	Approx. 102 VAC	AC LED (GRN)	ON	AC Good
Battery Trouble	Below 23.6 VDC	AC LED (GRN)	OFF	AC Bad
Battery Restoral	Above 25.0 VDC	DC LED (RED)	ON	AC Good, Battery Good
Battery Cutoff	Below 20.4 VDC	DC LED (RED)	OFF	AC Good, Battery Bad

Table 2: 504-24 Conditions

9.4 504-24 UL Listings

For UL 603 Power Supplies for Burglary Alarm Systems and UL294 Power Supplies for Access Control System applications: Voltage Range of 22.9 to 25.5 VDC.

For UL1481 Power Supplies for Fire Protective Signaling the following maximum battery standby Ampere hours apply for 24 hours of battery backup: Battery Standby Maximum: 49.2 AH
 Output Voltage: 24 VDC
 Output Current: 1.5A standby, 4 Amp alarm

9.5 24 VDC NAC Standby Battery Calculations

The following calculation defines the total number of standby battery Amp.hours required to support operation of the NACs and any other devices attached to the 504-24 power supply. From this calculation, assemble the appropriate number of batteries that will just exceed the calculated total Amp/hour requirement. The 866 NACs receive power for internal operation from the XR2400F panel and do not enter in this calculation themselves.

1. Add all standby current values including the power supply operating current.
2. Multiply the total standby current by the number of standby hours needed.
3. Add all alarm current values from the notification appliances attached to the 866 NACs and multiply by 0.25.
4. Add the total alarm mA. hour with the total standby mA. hour and then multiply this number by .001.

	Power supply operating current	200	mA
	Other standby current	+ _____	mA
1.	Total standby current	= _____	mA
	No. of standby hours required	X _____	hr
2.	Total standby (mA.hr required)	= _____	mA.hr
3.	Total alarm current	= _____	mA
	Total alarm current X .25	= _____	mA.hr
	(.25 = 5 minute alarm)		
	Total standby (required)	+ _____	mA.hr
	Total	= _____	mA.hr
		X .001	
4.	Total required Amp.hrs	= _____	

Table 3: Battery Calculations

9.6 Connection

The 24 VDC power supply is completely pre-wired. Refer to the following 504-24 wiring diagram for specific wire connections.

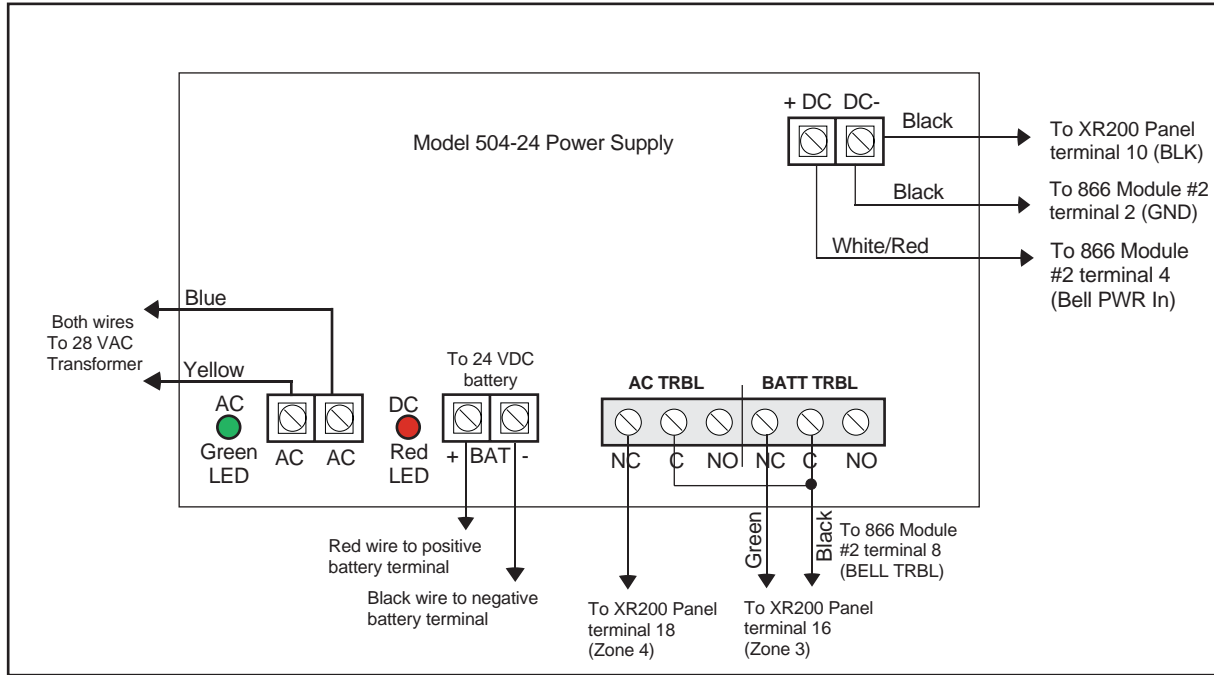

Figure 9: 504-24 Wiring Diagram

Interconnect Wiring Harness

10.1 Interconnect Harness

This chart explains the colors of the wires on the Interconnect Wiring Harnesses. It also explains what each wire connects.

Color	From	To
Red	Panel terminal 7 (DC Power)	866 Module #2 terminal 1 (AUX PWR)
Black	Panel terminal 10 (Common)	504-24 DC-
Brown	Panel terminal 13 (Zone 1)	866 Module #1 terminal 7 (Bell Trouble)
Violet	Panel terminal 15 (Zone 2)	866 Module #2 terminal 7 (Bell Trouble)
Green	Panel terminal 16 (Zone 3)	504-24 Battery Trouble terminal N/O
White	Panel terminal 18 (Zone 4)	504-24 AC Trouble terminal N/C
Blue	Panel J2 pin 2 (Common)	866 Module #1 terminal 3 (Alarm In)
Orange	Panel J2 pin 3 (Output 1 N/O)	Panel terminal 5 (Bell Output)
Yellow	Panel J2 pin 5 (Common)	866 Module #2 terminal 3 (Alarm In)
Orange	Panel J2 pin 6 (Output 2 N/O)	Panel terminal 5 (Bell Output)
White/Red	504-24 DC+	866 Module #2 terminal 4 (Bell PWR In)
Black	504-24 DC-	866 Module #2 terminal 2 (GND)
Red	866 Module #2 terminal 1 (AUX PWR)	866 Module #1 terminal 1 (AUX PWR)
Black	866 Module #2 terminal 2 (GND)	866 Module #1 terminal 2 (GND)
Black	866 Module #2 terminal 2 (GND)	866 Module #1 terminal 8 (Bell Trouble)
White/Red	866 Module #2 terminal 4 (Bell PWR In)	866 module #1 terminal 4 (Bell PWR In)
Black	866 Module #2 terminal 8 (Bell Trouble)	504-24 Battery Trouble terminal Common
Black	866 Module #2 terminal 8 (Bell Trouble)	866 Module #1 terminal 8 (Bell Trouble)

Table 4: Interconnect Wiring Harness

Fire Command Center

11.1 Description

The XR2400F provides an LCD display and 20-key keyboard for programming and user operation of the system. The Fire Command Center is installed on a mounting plate for easy access through the enclosure door. To the left of the keyboard, a keyswitch has been installed and pre-wired. The user must turn the keyswitch to enable the four function keys. See the illustration below.

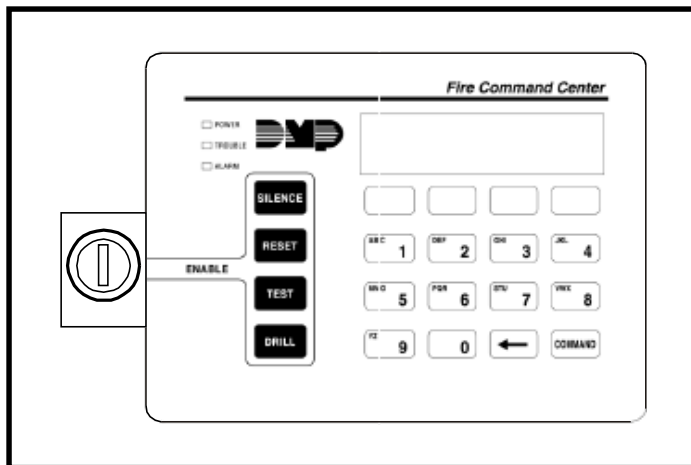

Figure 10: Fire Command Center keyboard and display

11.2 Connection

The display and keyboard are factory pre-wired to terminals 7, 8, 9, and 10 of the XR2400F panel. For standby battery calculations, the display draws 100mA of current in normal standby or alarm condition. See **Panel Standby Battery Calculations**. The keyswitch has been pre-wired to the membrane keyboard.

11.3 Remote Fire Command Center

Up to seven Model 630F Remote Fire Command Centers may be remotely attached to the XR2400F system. See 630F Installation Guide, LT-0562, for complete information.

XR2400F Command Processor Panel

12.1 Description

The DMP XR2400F Command Processor is a versatile fire communicator panel with battery backup. The XR2400F provides eight on-board grounded zones for connection of Model 869 class A zones and two on-board 12 VDC class B style A powered zones. The powered zones have a reset capability to provide for 2-wire smoke detectors, relays, or other latching devices. The XR2400F can communicate to one or two DMP SCS-1 Receivers using multiplex or digital dialer, or to non-DMP receivers using the Contact ID and Modem IIe formats.

12.2 Connection

The XR2400F Command Processor panel is factory pre-wired and controls the other components in the system. Refer to the wiring diagram below for wiring. See the following sections for descriptions of additional applications of the XR2400F.

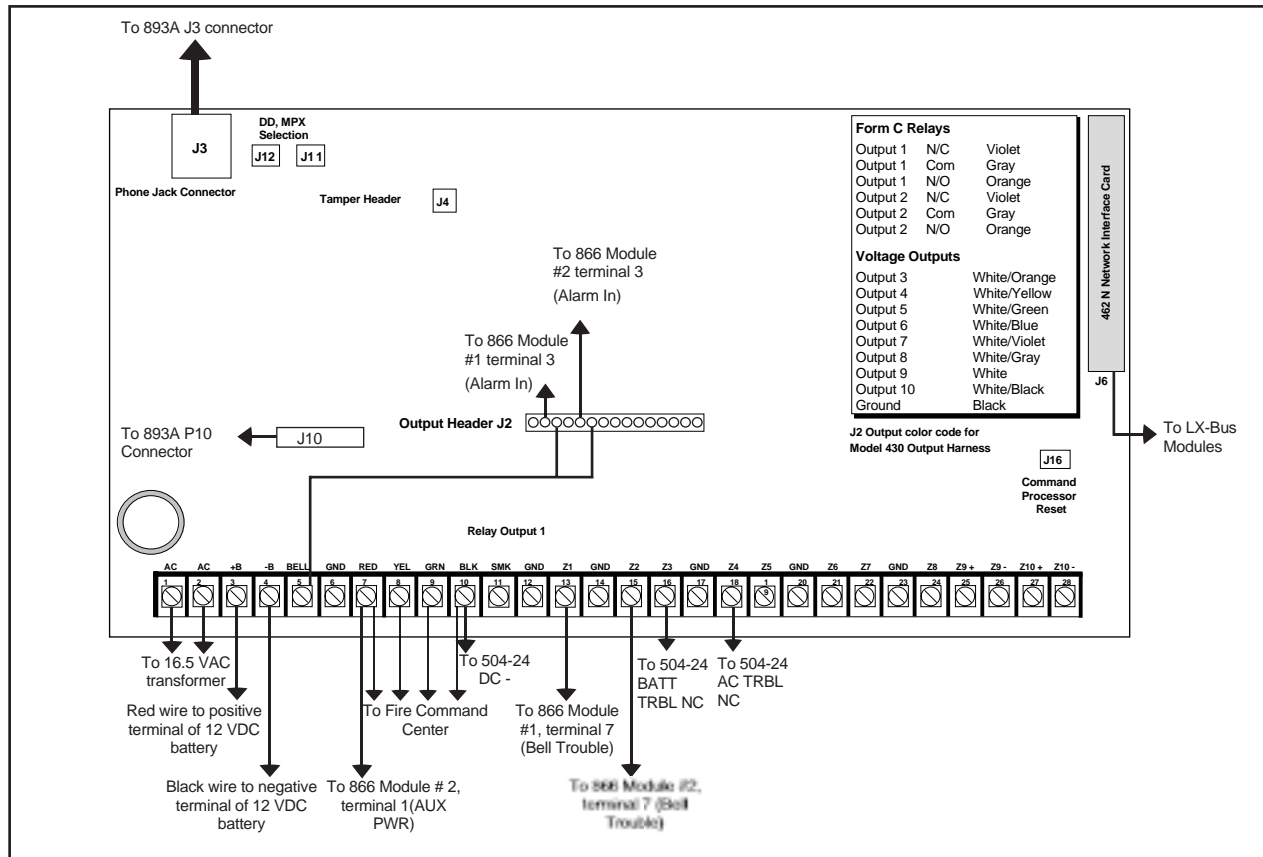

Figure 11: XR2400F Panel Wiring Diagram

12.3 Relays

The XR2400F is shipped with two Model 305 Relays pre-installed to allow zone alarm control for the 866 NAC Modules. When a fire alarm occurs the bell output is factory programmed to turn on and provide power to the contacts of the relays. Specific zone programming determines whether one or both relays turn on signal voltage to the 866 NACs. This allows control of the NACs by zone.

12.4 Zone Reference

The XR2400F has been pre-wired in the factory. The first 866 NAC module connects to Zone 1. The second 866 NAC module connects to Zone 2. Zone 3 is connected to the 504-24 power supply.

XR2400F Product Specifications

13.1 Power supply

Transformer Input: 16.5 VAC 100VA

Standby Battery: 12 VDC 28Ah (100VA charges up to four batteries)

Auxiliary: 12 VDC output at 1 Amp

Bell Output: 12 VDC at 1.5 Amp

All circuits are inherent Power Limited except the red battery wire.

13.2 Communication

Built-in dialer communication to DMP Model SCS-1 Receivers

Built-in multiplex communication to DMP Model SCS-1 Receivers

Built-in Contact ID communication to non-DMP receivers

Built-in Modem IIe communication to non-DMP receivers

893A Dual Phone Line Modules with phone line supervision

Can operate as a local panel

13.3 Panel zones

Eight 1k Ohm EOL grounded zones (zones 1 to 8). Connect to 869 class A module or burglary applications.

Two 3.3k Ohm EOL Class B (Style A) powered zone with reset (zones 9 and 10)

13.4 Remote Annunciator

You can connect up to seven of the following supervised keypads or expanders to the XR2400F keypad data bus:

- Alphanumeric Fire Command Centers or keypads
- Four and single point zone expanders
- Single point detectors

13.5 LX-Bus™

You can connect the following devices to the LX-Bus provided by the DMP 462N (supplied), 462P, 472, and/or 481 Interface Cards up to the maximum number of LX-Bus addresses. See **Accessory Devices**.

- Model 521LX or 521LXT Smoke Detectors with CleanMe
- Sixteen, eight, four, and single point zone expanders
- Relay output expanders
- Graphic annunciator modules
- Single point detectors

13.6 Outputs

Two SPDT relay outputs (requires two Model 305 relays that are provided on the panel, each rated 1 Amp at 30 VDC resistive). Connect only power limited sources to the relay.

Expansion

14.1 Expansion zones

Up to 232 additional fire and burglary zones are available on the XR2400F using the remote zone capability of keypads and zone expander modules. The panel's keypad data bus supports up to eight supervised device addresses with each address supporting up to four programmable expansion zones.

Up to 200 zones are available using the Model 460 Interface Adaptor, 462N, 462P, 472, or 481 Interface Cards, and any combination of sixteen, eight, four, and single point zone expander modules and single point LX-Bus™ detectors.

Combined current requirements of additional modules may require an additional 504-24 or 502-12 power supply. See section **Standby Battery Calculations** when calculating power requirements.

14.2 Output (relay) expansion

In addition to the two SPDT relays and eight voltage outputs on board the XR2400F, you can also connect up to 25 Model 716 Output Expanders to each card's LX-Bus™. These modules can provide an additional 200 programmable SPDT relays. The XR2400F provides 50 Output Schedules you can use for programming the 716 to perform a variety of annunciation and control functions. You can also assign the 716 outputs to any of the panel's Output Options such as Fire Alarm, Communication Fail, or Phone Trouble Outputs.

The LX-Bus also supports the Model 717 Graphic Annunciator Module. Each 717 module supplies 20 switched ground outputs that follow the state of their assigned zones.

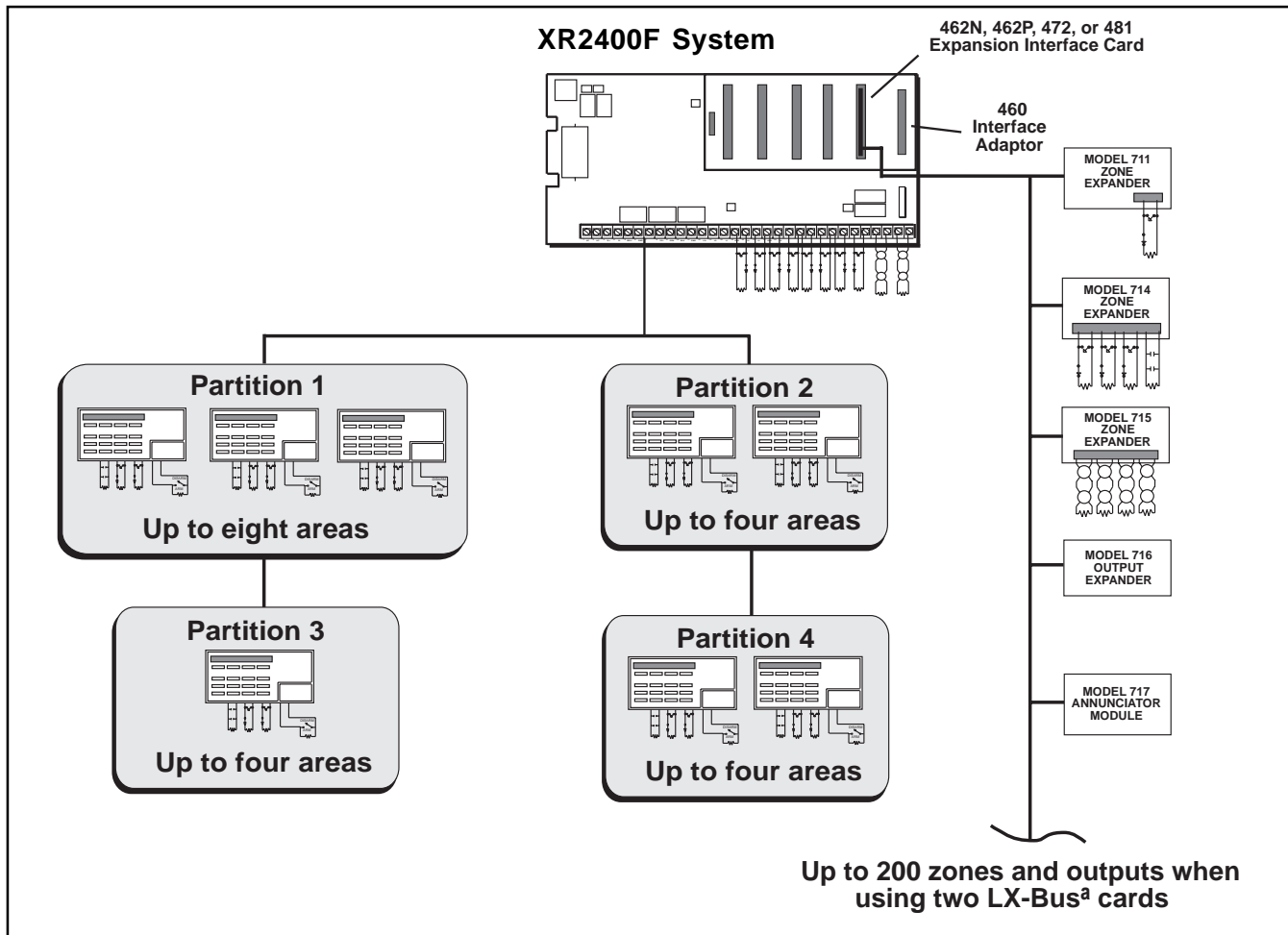

Figure 12: Typical XR2400F Expansion

Accessory Devices

15.1 Wiring diagram

The XR2400F system below shows some of the accessory modules you can connect for use in various applications. A brief description of each module appears in section **Accessory Devices**.

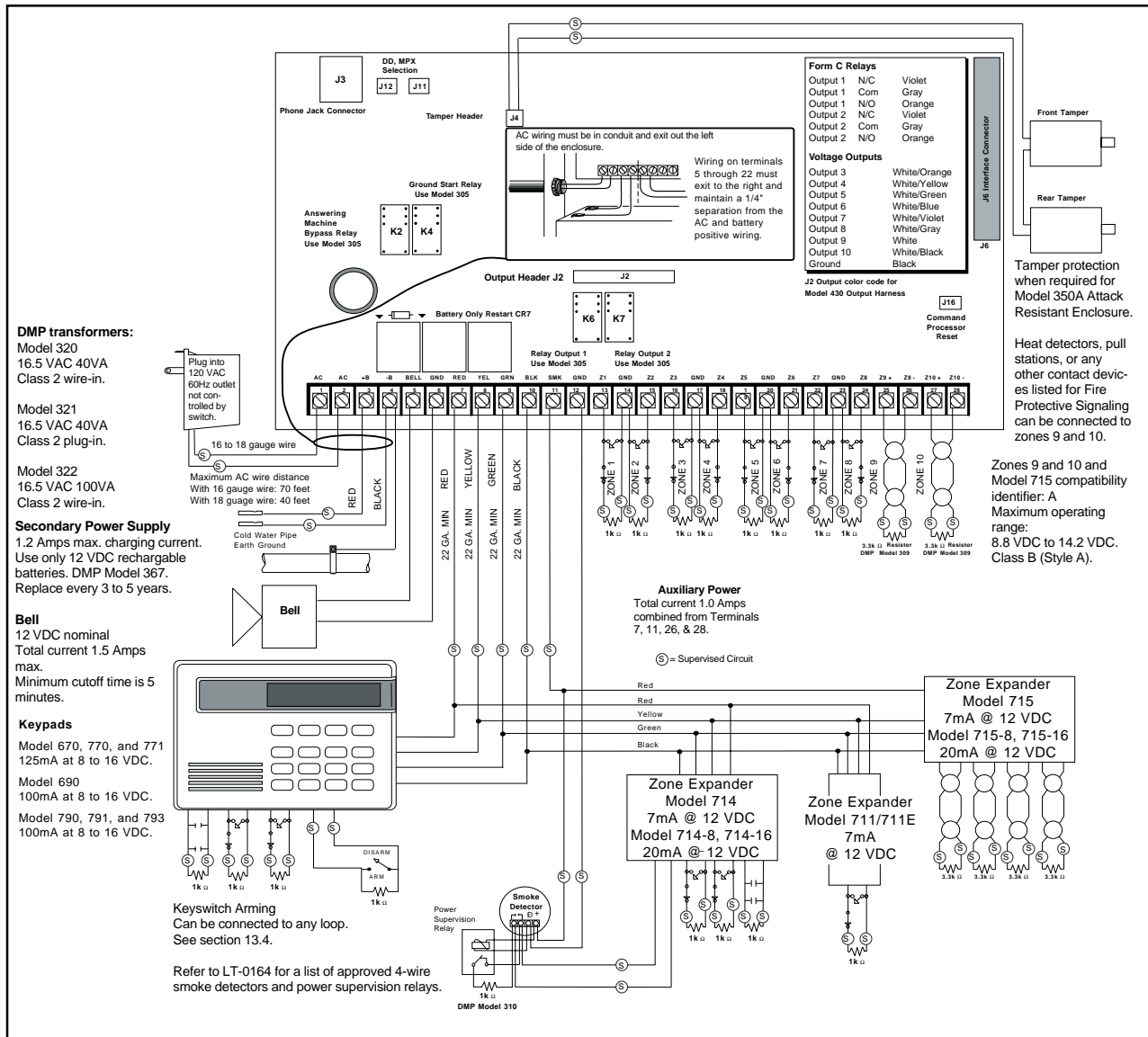

Figure 13: Typical XR2400F Wiring Diagram

15.2 Lightning protection

Metal Oxide Varistors and Transient Voltage Suppressors help protect against voltage surges on input and output circuits of the XR2400F. Additional surge protection is available by installing the DMP 370 or 370RJ Lightning Suppressors.

15.3 Accessory Devices

Model	Description
Interface Adaptor and Plug-in Cards	
460 Interface Adaptor	Allows you to connect two or more expansion interface cards to the XR2400F panel. The 460 is an expansion mother board that plugs into the J6 Interface Connector of the XR2400F panel and is required when connecting two or more expansion interface cards. You can use any combination of the following cards for expanding zones, network interfacing, local printing, and connecting wireless devices.
462N Network Interface Card	Allows you to connect the XR2400F to any compatible data network and use its communication capability in place of standard dial out telephone lines. The 462N also provides an LX-Bus™ for connecting zone and output expansion modules to the panel. The 462N is listed for Grade AA Burglary communication and supplementary signaling.
462P Printer Interface Card	Allows you to connect the XR2400F to any compatible serial printer providing real-time event recording to the user. The 462P also provides an LX-Bus™ for connecting zone and output expansion modules to the panel.
472 Hard-wire-less Interface Card	Provides an interface between the Inovonics FA400 Wireless Receiver and the panel. You can use any of the wireless equipment compatible with the FA400 to construct a strictly wireless or combined wireless/hardwire system. Wireless functionality is listed for Household Fire and Burglary. The 472 also provides one LX-Bus™ for connecting zone and output expansion modules.
481 Expansion Interface Card	Provides one LX-Bus™ for connecting up to 100 expanded zones and outputs to the XR2400F panel.
Zone and Output Expansion Modules	
710 Bus Splitter/Repeater	Allows you to expand the typical LX-Bus™ installation both in the number of devices and length of wire used.
711/711E Single Point Zone Expanders	Provides one Class B zone for connecting non-powered fire devices.
714, 714-8, 714-16 Zone Expanders	Provides Class B zones for connecting non-powered fire devices.
715, 715-8, 715-16 Zone Expanders	Provides 12 VDC Class B powered zones for connecting smoke detectors and other 2- or 4-wire devices.
716 Output Expander	Provides four Form C relays (SPDT) and four switched grounds (open collector) for use in a variety of remote annunciation and control applications.
717 Graphic Annunciator Module	Provides 20 zone following annunciator outputs (open collector) for use in a variety of remote annunciation and control applications.
Indicating and Initiating Devices	
865 Supervised Style Y or Z Notification Circuit Module	Provides up to 1.5 Amps of supervised alarm current when using the bell output of the XR2400F panel and up to 5 Amps at 12 or 24 VDC when using a listed auxiliary power supply. The 865 can supervise 2-wire Style Y or W circuits or X circuits for ground faults, opens, shorts, and shorts with individual LED annunciation.
866 Notification Circuit Module (Two provided)	Provides up to 1.5 Amps of supervised alarm current using the bell output of the XR2400F panel and up to 5 Amps at 12 or 24 VDC when using a listed auxiliary power supply. The 866 can supervise Style W circuits for opens and shorts.
867 Style W LX-Bus Notification Circuit Module	Provides up to 1.5 Amps of supervised alarm current using the bell output of the XR2400F panel and up to 5 Amps at 12 or 24 VDC when using a listed auxiliary power supply. The 867 connects to the LX-Bus™ of the XR2400F panel and provides one 2-wire Style W notification circuit for ground fault, open, and short conditions. Individual Bell Relay addresses Bell Ring styles.
869 Dual Style D Initiating Module	Provides two Style D, 4-wire initiating zones for connecting waterflow switches and other non-powered fire devices.
Accessory Modules and Keypads	
893/893A Dual Phone Line Modules (One 893A provided)	Allows you to supervise two standard phone lines connected to an XR2400F panel. The 893 and 893A modules monitor the main and backup phone lines for a sustained drop in voltage and alerts users when voltage drops below 3 VDC.
630F Remote Fire Command Center	Allows you control the XR2400F panel from various remote locations. You may connect up to seven 630F Remote Fire Command Centers to the keypad data bus on terminals 7, 8, 9, and 10.
Security Command® Vacuum Fluorescent keypads	Allows you to control the panel from various remote locations. You may connect up to eight supervised Model 670, 770, or 771 Security Command® keypads the keypad data bus on terminals 7, 8, 9, and 10. Use an auxiliary power supply when connecting more than five keypads or installing excessively long wire runs.
Security Command® LCD keypads	Allows you to control the panel from various remote locations. You may connect up to eight supervised Model 690, 790, 791, and 793 Security Command® keypads the keypad data bus on terminals 7, 8, 9, and 10. Use an auxiliary power supply when connecting more than five keypads or installing excessively long wire runs.

15.4 Mounting keypads and zone expanders

Security Command keypads have removable covers that allow you to easily mount the keypad to a wall or other flat surface using the screw holes provided on each corner of the base. Before mounting the base, connect the keypad wire harness leads to the keypad cable from the panel and to any device wiring run to that location. Then attach the harness to the pin connector on the PC board, mount the base, and install the keypad cover making sure all of the keys extend through their respective holes.

For mounting keypads on solid walls, or for applications where conduit is required, use a DMP 775 or 776 keypad conduit backbox for 770 series keypads. To provide additional protection for the keypad against unauthorized access, you can install the 777 Plastic Keypad Cover that provides a clear 1/8" thick polycarbonate housing with locking mechanism.

For the 790 series keypads, you can use the Model 695 1-1/2" deep or the Model 696 1/2" deep backboxes.

The DMP 711, 711E, 714, 715, 716, and 717 modules are each contained in molded plastic housings with removable covers. The housing cover contains the module while the base provides you with two mounting holes for installing the unit to a wall, switch plate, or other surface.

15.5 Connecting serial devices

Refer to the 710 Bus Splitter/Repeater Installation Sheets, LT-0310 (Document No. 0310 on DMP Fax) for information concerning keypad and LX-Bus wiring distances and capacities.

Keypad Data Bus

The keypad data bus requires only a 4-wire cable between devices and the panel. You can connect devices in parallel on the same cable or provide separate runs back to the panel. The maximum cable length for one keypad can be up to 500 feet using 22 gauge wire or up to 1000 feet using 18 gauge wire. Additional keypads installed on the same cable decrease the maximum distance at which they will operate properly.

Refer to Figure 15: Typical XR2400F Wiring Diagram for additional wiring information.

Expansion Interface Cards (Models 462N, 462P, 472, 481, and 482)

The LX-Bus provided on these cards also requires only a 4-wire cable between the card and any devices connected to the bus. You can connect devices (zone or output expanders) together on the same cable or provide separate runs back to the cards. You can determine the maximum length of each wire run by totaling the number of devices against the size wire used. Up to 100 zones or relays are available on each LX-Bus.

The XR2400F supports two LX-Bus' to provide up to 200 class B style 3.5 alarm points. You can connect up to 100 Model 521LX or 521LXT smoke detectors directly to the 4-wire cable. These detectors are individually addressable to provide specific alarm point information of a fire.

Battery Information

16.1 Battery only restart

When powering up the XR2400F panel without AC power, it is necessary to short across the CR7 leads to pull in the battery cutoff relay. The leads need a momentary short only. Once the relay has pulled in, the battery voltage holds it in that condition. If the XR2400F panel is powered up with an AC transformer, the battery cutoff relay is pulled in automatically.

16.2 Replacement period

DMP recommends the battery be replaced every 3 to 5 years under normal use.

16.3 Discharge/recharge

The XR2400F battery charging circuit float charges at 13.9 VDC at a maximum current of 1.2 Amps using a 40VA transformer. The total current available is reduced by the combined auxiliary current draw from terminals 5, 6, and 24. The various battery voltage level conditions are listed below:

Battery Trouble:	Below	11.9 VDC
Battery Cutoff:	Below	10.2 VDC
Battery Restored:	Above	12.6 VDC

16.4 Battery supervision

The XR2400F tests the battery when AC power is present. The test is done every 3 minutes and lasts for five seconds. During the test, the panel places a load on the battery and if its voltage falls below 11.9 VDC a low battery is detected. If AC power is not present, a low battery is detected **any time** the battery voltage falls below 11.9 VDC.

If a low battery is detected with AC power present, the test is repeated every two minutes until the battery charges above 12.6 VDC; the battery restored voltage. If a weak battery is replaced with a fully charged battery, the restored battery will not be detected until the next two minute test is done.

16.5 Battery cutoff

The panel disconnects the battery any time the voltage of the battery drops below 10.2 VDC. This prevents deep discharge damage to the battery.

16.6 XR2400F power requirements

During AC power failure, the XR2400F panel and all auxiliary devices connected to the XR2400F draw their power from the battery. All devices must be taken into consideration when calculating the battery standby capacity. On the following page is a list of the power requirements of the XR2400F panel. First add the current draw of the devices included in the XR2400F FACP:

- XR2400F Command Processor™ Panel
- The Fire Command Center
- 893A
- Two 866 NAC modules
- The 462N Card

Then add the additional current draw of Remote Fire Command Centers, zone expanders, smoke detector output, and any other auxiliary devices used in the system for the total current required. The total is then multiplied by the number of standby hours required to arrive at the total ampere/hours required.

See the Panel Standby Battery Power Calculations chart on the following page.

STANDBY BATTERY POWER CALCULATIONS		Standby Current	Alarm Current
XR2400F Control Panel		80mA _____ mA	80mA _____ mA
Relay Outputs 1-2 (ON)	Qty _____ x	30mA _____	Qty _____ x 30mA _____
Voltage Outputs 3-10 (ON)	Qty _____ x	5mA _____	Qty _____ x 5mA _____
Active Zones 1-8	Qty _____ x	1.6mA _____	Qty _____ x *2mA _____
Active Zones 9-10	Qty _____ x	4mA _____	Qty _____ x 30mA _____
2-Wire Smokes	Qty _____ x	.1mA _____	Qty _____ x .1mA _____
Panel Bell Output			500mA _____
893/893A Dual Phone Line Module		12mA _____	50mA _____
460 Interface Adaptor Card		7mA _____	7mA _____
462N Network Interface Card	Qty _____ x	50mA _____	Qty _____ x 50mA _____
462P Printer Interface Card	Qty _____ x	50mA _____	Qty _____ x 50mA _____
472 HARD-WIRE-LESS Interface Card	Qty _____ x	85mA _____	Qty _____ x 85mA _____
481 Expansion Interface Card	Qty _____ x	15mA _____	Qty _____ x 15mA _____
485 Access Control Interface		45mA _____	45mA _____
865 Style Y or Z Notification Module	Qty _____ x	26mA _____	Qty _____ x 85mA _____
866 Style W Notification Module	Qty _____ x	45mA _____	Qty _____ x 75mA _____
867 LX-Bus Style W Notification Module	Qty _____ x	30mA _____	Qty _____ x 85mA _____
630F, 690, 790, 791, 793	Qty _____ x	100mA _____	Qty _____ x 100mA _____
Active Zones (EOL installed)	Qty _____ x	1.6mA _____	Qty _____ x *2mA _____
670, 770, 771 Keypads	Qty _____ x	100mA _____	Qty _____ x 100mA _____
Annunciator (ON)			Qty _____ x 20mA _____
Active Zones (EOL installed)	Qty _____ x	1.6mA _____	Qty _____ x *2mA _____
733 Wiegand Interface	Qty _____ x	30mA _____	Qty _____ x 30mA _____
Annunciator (ON)			Qty _____ x 20mA _____
Active Zones (EOL installed)	Qty _____ x	1.6mA _____	Qty _____ x *2mA _____
736P Radionics Popit Interface	Qty _____ x	25mA _____	Qty _____ x 25mA _____
Radionics Popex, Octopopit, Popits	Qty _____ x	_____ mA _____	Qty _____ x _____ mA _____
738A Ademco Wireless Interface w/Receiver	Qty _____ x	75mA _____	Qty _____ x 75mA _____
740/741/743 SC Keypads	Qty _____ x	50mA _____	Qty _____ x 100mA _____
Active Zones (EOL installed)	Qty _____ x	1.6mA _____	Qty _____ x *2mA _____
Annunciator (ON)			Qty _____ x 20mA _____
710 Bus Splitter/Repeater	Qty _____ x	30mA _____	Qty _____ x 30mA _____
711, 711E, or 714 Zone Expander	Qty _____ x	7mA _____	Qty _____ x 7mA _____
Active Zones (EOL installed)	Qty _____ x	1.6mA _____	Qty _____ x *2mA _____
714-8 or 714-16 Zone Expander	Qty _____ x	20mA _____	Qty _____ x 20mA _____
Active Zones (EOL installed)	Qty _____ x	1.6mA _____	Qty _____ x *2mA _____
715 Zone Expander	Qty _____ x	7mA _____	Qty _____ x 7mA _____
Active Zones (EOL installed)	Qty _____ x	4mA _____	Qty _____ x *30mA _____
2-Wire Smokes	Qty _____ x	.1mA _____	Qty _____ x .1mA _____
715-8 or 715-16 Zone Expander	Qty _____ x	20mA _____	Qty _____ x 20mA _____
Active Zones (EOL installed)	Qty _____ x	4mA _____	Qty _____ x *30mA _____
2-Wire Smokes	Qty _____ x	.1mA _____	Qty _____ x .1mA _____
716 Output Expander	Qty _____ x	7mA _____	Qty _____ x 7mA _____
Active Form C Relays			Qty _____ x 28mA _____
717 Graphic Annunciator	Qty _____ x	10mA _____	Qty _____ x 10mA _____
Annunciator Outputs			Qty _____ x 1mA _____
521LX and LXT Smoke Detectors	Qty _____ x	8.8mA _____	Qty _____ x 28mA _____
Aux. Powered Devices on Terminals 7 and 11 (Other than keypads and LX-Bus modules)		_____ mA	_____ mA
		Total Standby _____ mA	Total Alarm _____ mA
Total Standby _____ mA x Number of standby hours needed _____ = _____ mA/hours			
		Total Alarm + _____ mA/hours	
		Total _____ mA/hours	
* Based on 10% of active zones in alarm condition		x .001	
Cannot exceed 7.7 Ah with one 367 Battery		= _____ Amp/hrs Required	
Cannot exceed 15.4 Ah with two 367 Batteries			
Cannot exceed 23.1 Ah with three 367 Batteries			
Cannot exceed 30.8 Ah with four 367 Batteries			

Bell Output

17.1 Terminals 5 and 6

Terminal 5 supplies positive 12 VDC to power alarm bells or horns. The output is rated for a maximum output of 1.5 Amps. This output can be steady or pulsed or temporal code 3 depending upon the Bell Action specified in Output Options. Terminal 6 is the ground reference for the bell circuit.

Keypad and Zone Expander Bus

18.1 Description

Terminals 7, 8, 9, and 10 of the XR2400F panel are for the keypad data bus. In addition to Fire Command Centers and Remote Fire Command Centers, you can also connect any combination of up to eight zone expanders, 5845LX Glassbreak detectors, 6155LX PIRs, and DS775LX PIRs to the data bus.

18.2 Terminal 7 - RED

This terminal supplies positive 12 VDC to power Fire Command Centers and zone expanders. This is also where power for any auxiliary device is supplied. The ground reference for terminal 7 is terminal 10 with the maximum output rated at 1 Amp.

The output current is shared with the smoke detector output on terminal 11 and Zones 9 and 10. All devices totalled together must not exceed the panel's maximum current rating of 1 Amp.

18.3 Terminal 8 - YELLOW

Data receive from keypads and zone expanders. It cannot be used for any other purpose.

18.4 Terminal 9 - GREEN

Data transmit to keypads and zone expanders. It cannot be used for any other purpose.

18.5 Terminal 10 - BLACK

Terminal 10 is the ground reference for Fire Command Centers, zone expanders, and any auxiliary devices being powered by terminal 7.

Smoke Detector Output

19.1 Terminals 11 and 12

Terminal 11 supplies positive 12 VDC to power 4-wire smoke detectors and other powered devices. This output can be turned off by the user for 5 seconds using the Sensor Reset User Menu option to allow latched devices to reset. Terminal 12 is the ground reference for terminal 11.

19.2 Current rating

The Output current from terminal 11 is shared with terminals 7, 26, and 28. The total current draw of all devices powered from the panel must be included with terminal 11 calculations and must not exceed the maximum output rating of 1 Amp.

Powered Zones for 2-Wire Smoke Detectors

20.1 Terminals 25-26 and 27-28

Two resettable Class B (Style A) 2-wire powered zones are provided on terminals 25 through 28 on the panel. For programming purposes the zone numbers are 9 and 10.

The zones use a Model 309, 3.3k Ohm EOL resistor provided with the panel and have an operating range of 8.8 to 14.2 VDC.

The UL compatibility identifier for the zones is: A.

Do not mix detectors from different manufacturers on the same zone.

Manufacturer	Model	Detector ID	Base	Base ID	# of Detectors
Detection Systems	DS282	B	None	N/A	10
Detection Systems	DS282TH	B	None	N/A	10
Detection Systems	DS250	B	MB2W	A	10
Detection Systems	DS250TH	B	MB2W/MB2WL	A	10
Detection Systems	DS250HD	B	MB2W/MB2WL	A	10
Hochiki	SLK-12	HD-4	HSB-12-1, HSB-12-1N	HB-80	20
DMP/Hochiki	SLK-835	HD-5	HSB-200, HSB-200N	HB-55	7
DMP/Hochiki	SLK-835H	HD-5	HSB-200, HSB-200N	HB-55	7
DMP/Hochiki	SLR-835	HD-3	NS6-100	HB-55	7
DMP/Hochiki	SLR-835B	HD-6	None	N/A	7
Sentrol/ESL	429AT	S09A	None	N/A	12
Sentrol/ESL	521B	S09A	None	N/A	12
Sentrol/ESL	521BXT	S09A	None	N/A	12
System Sensor	1100	STD	None	N/A	10
System Sensor	1151	STD	B110LP	N/A	10
System Sensor	1400	STD	None	N/A	10
System Sensor	1451	STD	B401, B401B	N/A	10
System Sensor	2100	STD	None	N/A	10
System Sensor	2400	STD	None	N/A	10
System Sensor	2451	STD	B401, B401B, DH400	N/A	10
System Sensor	1451DH	STD	DH400	N/A	10
System Sensor	2100T	STD	None	N/A	10
System Sensor	2400AT	STD	None	N/A	10
System Sensor	2400AIT	STD	None	N/A	10
System Sensor	2400TH	STD	None	N/A	10
System Sensor	2451TH	STD	B401, B401B	N/A	10

Table 5: Compatible 2-wire smoke detectors

Protection Zones

21.1 Description

Zones 1 to 8 on the XR2400F panel (terminals 13 to 24) are all grounded burglary zones. For programming purposes, the zone numbers are 1 through 8. Terminals 13 to 24 provide connection as listed below.

Terminal	Function	Terminal	Function
13	Zone 1 voltage sensing	19	Zone 5 voltage sensing
14	Ground for Zones 1 & 2	20	Ground for Zones 5 & 6
15	Zone 2 voltage sensing	21	Zone 6 voltage sensing
16	Zone 3 voltage sensing	22	Zone 7 voltage sensing
17	Ground for Zones 3 & 4	23	Ground for Zones 7 & 8
18	Zone 4 voltage sensing	24	Zone 8 voltage sensing

Note: Zones 1 through 4 have been pre-wired to the two 866 NAC modules and the 504-24 power supply. All other zones are available.

The voltage sensing terminal measures the voltage through a 1k Ohm End Of Line resistor to ground. Dry contact sensing devices can be used in series (normally-closed) or in parallel (normally-open) with any of the burglary protection zones.

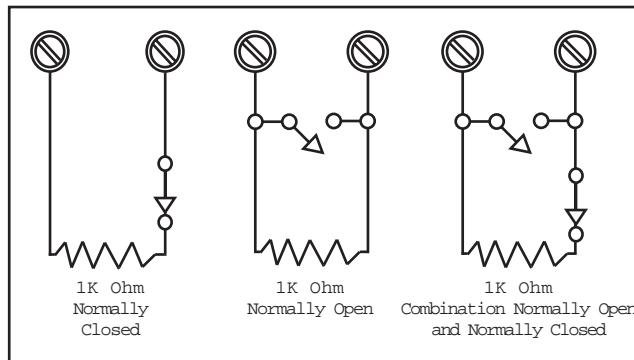

Figure 14: Protection zone contact wiring

21.2 Operational parameters

Each protection zone detects three conditions: open, normal, and short. The voltage and resistance parameters for each condition are listed below:

Condition	Resistance on zone	Voltage on positive terminal
Open	over 1300 ohms	over 2.0 VDC
Normal	600 to 1300 ohms	1.2 to 2.0 VDC
Short	under 600 ohms	under 1.2 VDC

21.3 Zone response time

A condition must be present on a zone for 500 milliseconds before it's detected by the XR200 panel. Ensure detection devices used on the protection zones are rated for use with this delay. The zones can also be programmed for a fast response delay of 160 milliseconds.

21.4 Keyswitch arming zone

Using a keyswitch on an Arming type zone allows you to arm and disarm selected areas without having to enter a user code.

Dry Contact Relay Outputs

22.1 Description

The XR2400F panel provides two auxiliary SPDT relays when equipped with two DMP Model 305 relays in sockets K6 (Output 1) and K7 (Output 2) and a Model 430 Output Harness. Each relay provides one single pole, double throw (SPDT) set of contacts that can be operated by any of the functions listed below:

- 1) Activation by zone condition
 - Steady
 - Pulsing
 - Momentary
 - Follow
- 2) Activation by 24 hour 7 day schedule
 - One on and one off time a day for each relay
- 3) Manually from the Fire Command Center menu
- 4) Communication failure
- 5) Armed area annunciation
- 6) Fire Alarm or Fire Trouble
- 7) Other system conditions. See the Programming Guide (LT-0196).

22.2 Contact rating

The Model 305 relay contacts are rated for 1 Amp at 30 VDC resistive. You can connect auxiliary power to the common terminal of Relay Output 1 by installing the gray harness wire to terminal 7.

22.3 Output Harness wiring

The relay contacts are accessible by installing the DMP 430 Output Harness on the 15-pin header labeled J2. The contact locations on the wire harness are shown below:

Contact	Color
Output 1 normally closed	Violet
Output 1 common	Gray
Output 1 normally open	Orange
Output 2 normally closed	Violet
Output 2 common	Gray
Output 2 normally open	Orange

The relay contacts must be connected to devices located within the same room as the XR2400F panel.

12 VDC Voltage Outputs 3 to 10

23.1 Description

The XR2400F also provides eight 12 VDC, 50mA resistive voltage outputs on J2 to power external relays or other devices. The voltage outputs are operated from the same functions as Outputs 1 and 2.

When connecting any devices to outputs 3 to 10, subtract the current draw of the device from the panel's available auxiliary power.

23.2 Output Harness wiring

The voltage outputs are accessible by installing the DMP 430 Harness on the 15-pin header labeled J2. The output locations are shown below:

Output	Color	Output	Color	Output	Color
3	White/Orange	6	White/Blue	9	White
4	White/Yellow	7	White/Violet	10	White/Black
5	White/Green	8	White/Gray	Ground	Black

Devices connected to the outputs must be located within the same room as the XR2400F panel.

Reset and Tamper Headers

24.1 J16 Reset Header

The reset header is located just above the terminal strip on the right side of the circuit board and is used to reset the microprocessor of the XR2400F. To reset the panel when first installing the system, install the reset jumper before applying power to the panel. After connecting the AC and battery, remove the reset jumper.

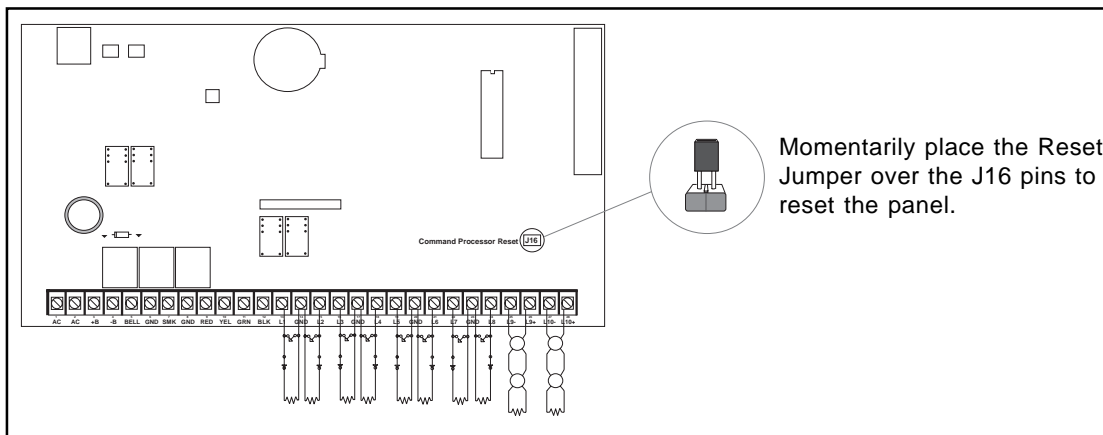

Figure 15: XR2400F panel showing reset

To reset the panel while the system is operational (for example, prior to reprogramming), install the reset jumper without powering down the system. Remove the reset jumper after one or two seconds.

After resetting the panel, you must begin programming within 30 minutes. If you wait longer than 30 minutes, you will have to reset the panel again.

24.2 J4 Tamper Header

The J4 header is for use with the optional DMP 306 Tamper Harness. The harness connects to one or more tamper switches mounted inside the panel enclosure to supervise against unauthorized opening or removal of the enclosure. Refer to the wiring diagram on the enclosure door for correct tamper switch wiring.

How the tamper works

If the enclosure is opened or removed while one or more of the system's areas are armed, a panel tamper alarm is indicated. If all areas are disarmed, a panel tamper trouble is indicated.

UNIVERSAL UL BURGLARY SPECIFICATIONS

25.1 Introduction

The programming and installation specifications contained in this section must be completed when installing the XR2400F panel in accordance with any of the UL burglary standards. Additional specifications may be required by a particular standard.

25.2 Wiring

All wiring must be in accordance with NEC, ANSI/NFPA 70, UL 681, and UL 611 for all burglary installations.

25.3 Control outside of protected area

A Potter EVD or Sentrol 5402 should be used in place of a lined cabinet when the panel is installed outside of the protected area.

25.4 Police station phone numbers

The digital dialer telephone number programmed for communication must not be a police station phone number, unless that phone number is specifically provided for that purpose.

25.5 Bypass reports

The Bypass Reports option must be programmed as YES for all UL burglary applications. See section 6.4 of the XR200 and XR2400F Programming Guide (LT-0196).

25.6 System maintenance

Proper installation and regular maintenance by the installing alarm company and frequent testing by the end user is essential to ensure continuous satisfactory operation of any alarm system. Offering a maintenance program and acquainting the user with the correct procedure for use and testing of the system is also the responsibility of the installing alarm company.

25.7 Partitions

The partition option may only be used for UL burglary applications when all partitions are used for one subscriber. See section 4.2 and 11.2 of the XR200 and XR2400F Programming Guide (LT-0196). The panel must be tamper protected and Sentrol Model 5402 or Potter EVD listed vibration detectors should be used.

25.8 UL Listed Receivers

UL has verified operation with the DMP SCS-1, Sur-Gard SG-HLR2-DG, FBII CP220PB, Osborne-Hoffman Quick-Alert, and Radionics D6500 receivers.

UL 1023 SPECIFICATIONS

Household Burglar-Alarm System Units

26.1 Bell cutoff

The Bell Cutoff time cannot be less than five minutes. See section 8.2 of the XR200 and XR2400F Programming Guide (LT-0196).

26.2 Entry delay

The maximum entry delay used must not be more than 45 seconds. See section 7.3 of the XR200 and XR2400F Programming Guide (LT-0196).

26.3 Exit delay

The maximum exit delay used must not be more than 60 seconds. See section 12.4 of the XR200 and XR2400F Programming Guide (LT-0196).

26.4 Weekly test

The product should be tested weekly.

UL 1610 AND 1076 SPECIFICATIONS

Central-Station and Proprietary Burglar-Alarm Units

27.1 Multiplex network capacity

The total number of panels assigned to a standard MPX or DNET receiving line of the SCS-1 Receiver System must not exceed 90. This may be increased to 180 by setting the SNRM option to NO in the SCS-1 Receiver system. This is to allow any signal from a XR2400F panel to be transmitted to the receiver within 90 seconds. This allows Grade AA Multiplex service.

27.2 Opening/Closing reports

The Opening/Closing Reports option must be programmed as YES. See section 12.6 of the XR200 and XR2400F Programming Guide (LT-0196).

27.3 Closing wait

The Closing Wait option must be programmed YES. See section 7.2 of the Programming Guide (LT-0196).

27.4 Proprietary dialer

The Model XR2400F provides Grade A proprietary service when configured as a digital dialer.

27.5 AA Network Communication

When HST network communication is used, a dialer line must also be used along with the Model 893 Dual Phone Line Module to supervise the dialer line. The HST network Check-in time must be set from 01 to 06 minutes or AA. This provides AA Central Station Service. See sections 3.2, 3.2.1, and 3.3 of the XR200 Programming Guide (LT-0196).

The Model XR2400F Protected Premises Control Unit is suitable for Grade AA service when configured for multiplex DNET or HST communication with SCS-1 receiving system. This configuration is approved for:

- AMCX - Central Station Alarm Units
- APAW - Police Station Alarm Units
- APOU - Proprietary Alarm Units

This approval is for communication over public data networks, provided that the protected premise (XR2400F) and receiving units (SCS-1) are listed. Additionally, the network device connected to the 462N Network Interface Card must be listed for UL Fire and Shock hazards.

For combined burglary and fire alarm systems, UL has an established set of requirements that specify certain hardware redundancies and communication protocols to ensure that indications of a fire or burglary are properly transmitted at the time of their occurrence.

Typically in a combined system, two dialer phone lines are dedicated to the alarm. This limits the interruption of normal business phone traffic caused by supervisory communication requirements of the alarm system. With the DMP system communicating over a data network however, this interruption of business phones is avoided by the panel's ability to send its traffic at any time directly over the network. The business phone lines are then used only to send a nightly Recall Test report or the report of an actual alarm to the central monitoring station. This eliminates the monthly expense of two phone lines dedicated to the alarm.

The DMP products meeting the UL requirements include the listed Model 893 Dual Phone Line Module used in supervising two separate analog phone lines and the Model 462N Network Interface Card listed as a supplementary signaling device for commercial fire systems.

If the requirement for the two dedicated phone lines is made by the local AHJ for the purpose of avoiding situations where the burglary/fire alarm system is incapable of communicating, the DMP panels have a built-in ability to seize the phone line and interrupt any call in progress as required by NFPA and UL. Instructions to the system installer for correctly wiring of the telephone jacks is also included in all DMP installation guides as an added measure of ensuring the system's communicating ability.

UL 1635 SPECIFICATIONS

Digital Burglar Alarm Communicator System Units

28.1 System trouble display

The Status List Display must include at least one keypad that displays system monitor troubles. See section 10.1 of the XR200 and XR2400F Programming Guide (LT-0196).

28.2 Digital Dialer telephone number

Both programmed telephone numbers must begin with a D or P. See sections 3.17 and 3.18 of the XR200 and XR2400F Programming Guide (LT-0196).

28.3 Entry delay

The maximum entry delay used must not be more than 60 seconds. See section 7.3 of the XR200 and XR2400F Programming Guide (LT-0196).

28.4 Exit delay

The maximum exit delay used must not be more than 60 seconds. See section 12.4 of the XR200 and XR2400F Programming Guide (LT-0196).

28.5 Test time

The Test Time option must be programmed so that the XR2400F sends a report once every 24 hours. See sections 3.8 to 3.10 of the Programming Guide (LT-0196).

28.6 Closing wait

The Closing Wait option must be programmed YES. See section 7.2 of the Programming Guide (LT-0196).

UL 365 AND 609 SPECIFICATIONS

Police Station Connected and Local Burglar Alarm Units and Systems

29.1 System trouble display

The Status List Display must include at least one keypad that displays system monitor troubles. See section 10.3 of the Programming Guide (LT-0196).

29.2 Grade A bell

A Grade A local audible signal appliance must be used.

29.3 Bell cutoff

The Bell Cutoff time cannot be less than 15 minutes. See section 8.2 of the Programming Guide (LT-0196).

29.4 Automatic bell test

The Automatic Bell Test option must be programmed as YES. See section 8.3 of the Programming Guide.

29.5 Line security for Police Connect

Basic line security is provided when the Model XR2400F is configured as a dialer system.

29.6 High Line Security

High Line Security is provided when configured as a MPX, DNET, or HST system. When HST communication is used, a dialer line must also be used along with the Model 893 Dual Phone Line Module to supervise the dialer line. The HST Check-in time must be set from 01 to 06 minutes or AA. See section **AA Network Communication** (27.5). Also see sections 3.2, 3.2.1, and 3.3 of the XR200 Programming Guide (LT-0196).

UNIVERSAL UL and NFPA FIRE ALARM SPECIFICATIONS

30.1 Introduction

The programming and installation specifications contained in this section must be completed when installing the Model XR2400F in accordance with any of the UL or NFPA fire standards. Additional specifications may be required by a particular standard.

30.2 Wiring

All wiring must be in accordance with NEC, ANSI/NFPA 70.

30.3 Transformer

A wire-in transformer should be used. Use the 16 VAC 40VA DMP Model 320. The transformer must be mounted within 20 feet of the panel connected by conduit.

30.4 End Of Line resistor

The DMP Model 310 1k Ohm EOL resistor should be used on all 1k Ohm EOL fire zones.

30.5 System trouble display

The Status List Display must include at least one keypad that displays system monitor troubles. See section 10.3 of the Programming Guide (LT-0196).

30.6 Fire display

The Status List Display must include at least one keypad that displays troubles and alarms on fire type zones. See section 10.4 of the Programming Guide (LT-0196).

30.7 Police station phone number

The digital dialer telephone number programmed for communication must not be a police station phone number, unless that phone number is specifically provided for that purpose.

30.8 System maintenance

Proper installation and regular maintenance by the installing alarm company and frequent testing by the end user is essential to ensure continuous satisfactory operation of any alarm system. Offering a maintenance program and acquainting the user with the correct procedure for use and testing of the system is also the responsibility of the installing alarm company.

30.9 Audible alarm

Fire Type zones should be programmed to activate an audible alarm. The Bell Action for Fire Type zones should not be programmed as "N". See section 8.4A in the Programming Guide (LT-0196).

30.10 Fire zone programming

If a retard delay is used on a waterflow zone, it cannot exceed 90 seconds and any retard delay in the waterflow initiating devices must be subtracted from the 90 seconds allowed. See sections 13.4 and 13.17 in the Programming Guide (LT-0196). The retard delay should not be used on a zone with smoke detectors.

30.11 Style D zones

If required, the DMP 869 Dual Style D Initiating Module provides for connection of two Style D zones to the Model XR2400F. See section **Dual Style D Zone Module Installation** in System Wiring Diagrams and the 869 Installation Guide (LT-0186) for wiring information.

30.12 Video Option

The Video option must be selected as NO when any fire protection is connected to the XR2400F. See section 7.9 in the Programming Guide (LT-0196).

30.13 UL Listed Receivers

UL has verified operation with the DMP SCS-1 (SDLC), Sur-Gard SG-HLR2-DG (CID, M2E), FBII CP220PB (CID), Osborne-Hoffman Quick-Alert (CID, M2E), and Radionics D6500 (M2E) receivers.

UL 985 NFPA 72 (Chapter 2) SPECIFICATIONS

Household Fire Warning System Units

31.1 Bell output definition

The Bell Output of the Model XR2400F must be programmed to operate steady on burglary alarms and pulsed or temporal on fire alarms. See section 8 of the Programming Guide (LT-0196).

UL 864 NFPA 72 (Chapter 9) SPECIFICATIONS

Control Units for Fire-Protective Signaling Systems

32.1 Zone restoral reports

The Restoral Reports option must be selected as YES or DISARM. See section 6.3 in the Programming Guide (LT-0196).

32.2 Power fail delay

The Power Fail Delay option must be selected as 6 hours. See section 7.6 of the Programming Guide (LT-0196).

32.3 Sprinkler supervisory

Any zone used for sprinkler supervisory must be programmed with "SPRINKLR XXX" as the zone name. The last three characters in the zone name may be assigned a number to identify the zone. The Model 893 or 893A Dual Phone Line Module must be used on all sprinkler supervisory systems.

32.4 DACT systems

Two phone lines must be used. The two phone lines cannot be ground start or party lines. The 893 or 893A Dual Phone Line Module is used to provide connection of two phone lines to the system. The 2ND Phone Line communication option must be selected as YES. See section 3.3 of the Programming Guide (LT-0196).

Two different phone numbers must be programmed for digital communication. See sections 3.17 and 3.18 of the Programming Guide (LT-0196). The Test Time option must be programmed so that the XR2400F sends a report every 24 hours. See sections 3.8 to 3.10 of the Programming Guide (LT-0196).

Additionally, you can use the 462N Network Interface Card and the HST (Host) Communication type for supplementary communication over digital data networks.

32.5 Type 2 and Type 3 Central Station Service

Type 2 and Type 3 Central Station Service can be provided by using MPX communication to the DMP SCS-1 Receiver system. See section 3.2 of the Programming Guide (LT-0196).

32.6 Type 1 Central Station Service

Type 1 Central Station Service can be provided by using MPX as the main communication and digital dialer as backup. The 893 Dual Phone Line Module is used to provide connection of the MPX and dialer lines. See section 3.2 of the Programming Guide (LT-0196). If Type 1 Central Station service is provided, the Test Time option must be programmed to send a report every 24 hours. See sections 3.8 to 3.10 of the Programming Guide (LT-0196).

With both Type 1 and Type 2 Central Station service, the total number of panels assigned to a standard MPX receiving line of the SCS-1 Receiver System must not exceed 90. This may be increased to 180 by setting the SNRM option to NO in the SCS-1 Receiver system. This is to allow any signal from a XR2400F to be transmitted to the receiver within 90 seconds.

32.7 Local Protective Signaling Systems

The DMP Model 865, 866, or 867 Notification Circuit Module must be used on the bell circuit for detection of shorts and grounds. See sections 25.1 to 25.3 for wiring diagrams. Model 770 series keypads that are used to display troubles for local fire alarm systems must be installed within a DMP Model 777 Keypad Protector. Model 790 series keypads that are used to display troubles for local fire alarm systems must be installed within a DMP Model 777 with 777S 1.0" spacer. Any burglary or other off premises communication must be done with the Model 893 or 893A Dual Phone Line Module.

32.8 Proprietary Protective Signaling Systems

The total number of panels assigned to one MPX or DNET receiving line of the DMP SCS-1 Receiver system must not exceed 90. This may be increased to 180 by setting the SNRM option to NO in the SCS-1 Receiver system. This allows any report from a XR2400F to be sent to the receiver within 90 seconds.

32.9 Remote Station Protective Signaling Systems

You must provide 60 hours of standby battery. Up to four 12 VDC, 6.5Ah batteries may be used. See section **Standby Battery Power Calculations**. Two Radionics Model D127 Reversing Relay Modules provide two reversing polarity telephone connections. See section **Remote Station Reversing Relay Connection** and the D127 Installation Instruction sheet for wiring details. A DMP Model 893 or 893A is used to provide two line dialer communication or Type 1 Multiplex communication.

CALIFORNIA STATE FIRE MARSHAL SPECIFICATIONS**33.1 Bell output definition**

The Bell Output of the XR2400F panel must be programmed to operate steady on burglary alarms and pulsed, temporal, or California School Code on fire alarms. See sections 8.4A and 8.4B of the Programming Guide (LT-0196).

System Wiring Diagrams

3.4.1 Multiple indicating circuit modules

To additional twenty-three 866 Indicating Circuit Modules. Up to a maximum of twenty-five 866 modules on the XR200 panel. All modules must be installed in a 340FC, 349, or 350 enclosure connected by no more than 20 feet of conduit.

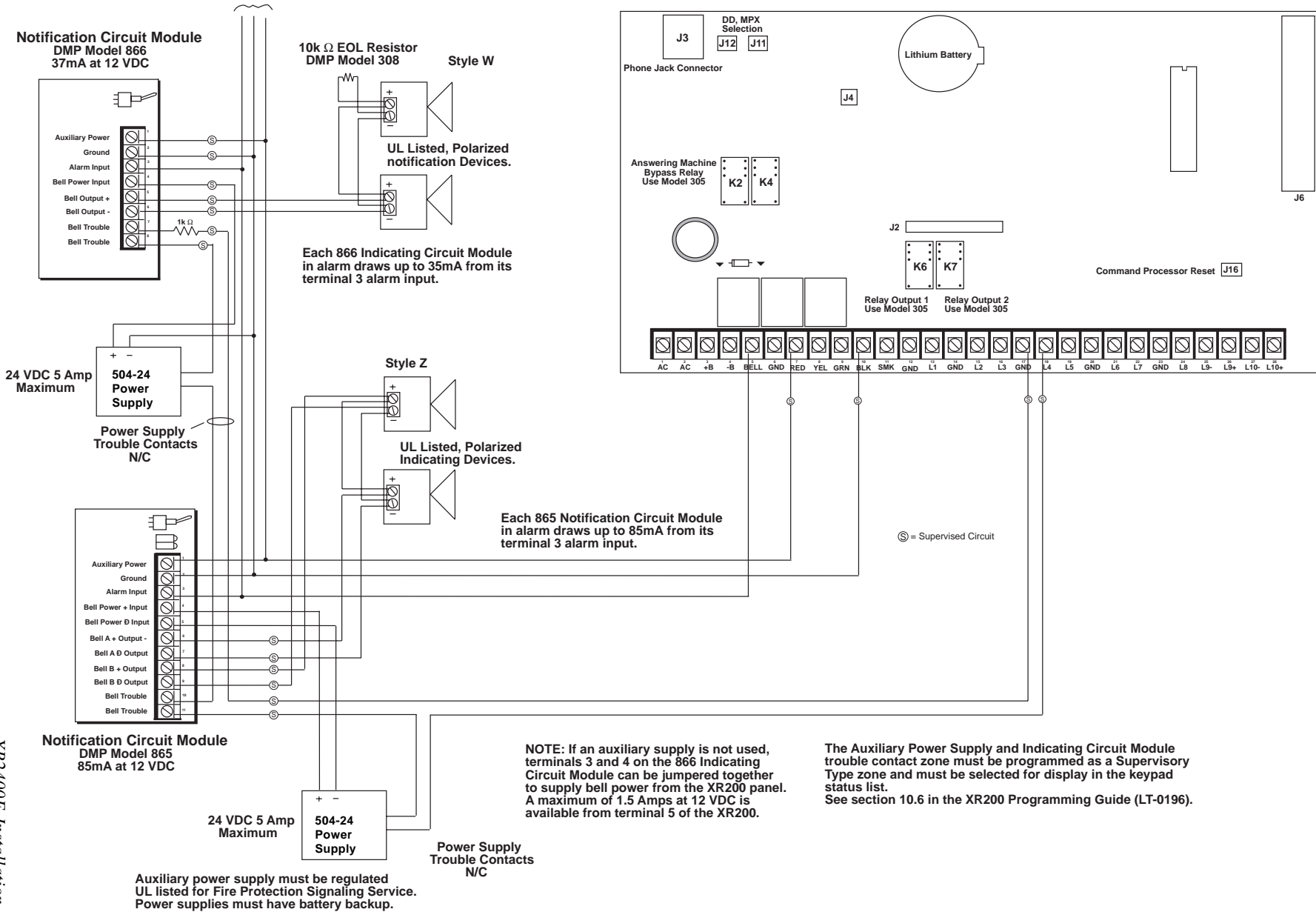

34.2 Multiple indicating circuit modules for zoned annunciation

You can have up to twenty-five 866 Indicating Circuit Modules by using the relay outputs available on the XR2400F panel.

All modules must be installed within a 340FC, 349, or 350 enclosure connected by no more than 20 feet of conduit.

To additional Zone 1 Indicating Circuit Modules.

Zone 1 Indicating Circuit Module. DMP Model 866
45mA at 12 VDC

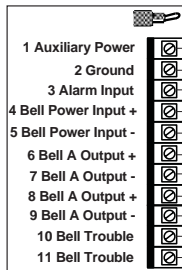
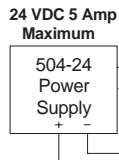
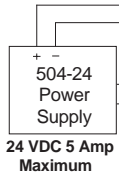
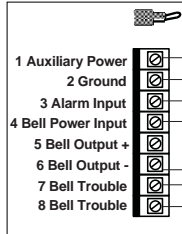

Zone 2 Indicating Circuit Module. DMP Model 865
26mA at 12 VDC

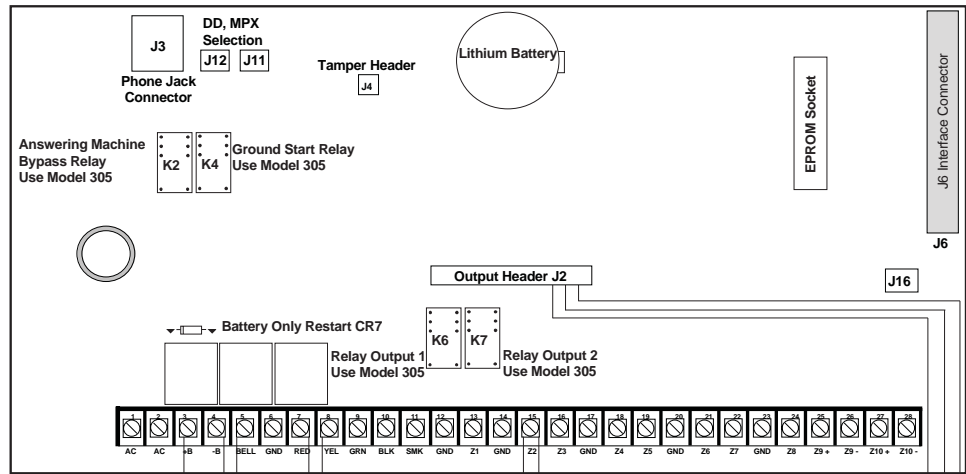

10k Ω EOL Resistor DMP Model 308

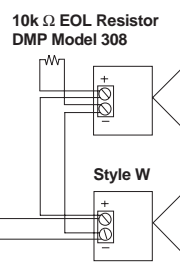
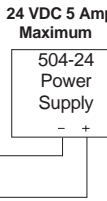
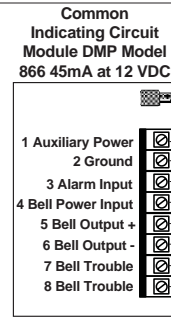
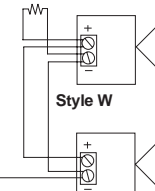

Auxiliary power supplies must be regulated UL listed for Fire Protection Signaling Service. Power supplies must have battery backup.

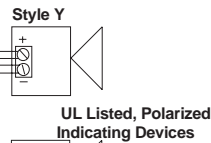

To additional Zone 2 Indicating circuit modules

Outputs 3 to 10 can switch up to 50mA each at 12 VDC. This is sufficient for one 866 module per indicating zone 3 to 10.

Zone 1 Output
Zone 2 Output
Model 430 Output Harness

Relays 1 and 2 Common Gray
Relay 1 N/O Orange
Relay 2 N/O Orange

The Auxiliary Power Supply and Indicating Circuit Module trouble contact zone must be programmed as a Supervisory Type Zone and must be selected for display in the keypad status list. See the XR200 and XR2400F Programming Guide (LT-0196).

NOTE: If an auxiliary supply is not used, terminals 3 and 4 on the 866 Indicating Circuit Module can be jumpered together to supply bell power from the XR2400F panel.

A Maximum of 1.5 Amps at 12 VDC is available from terminal 5 of the XR2400F

34.3 Dual Style D Zone Module installation

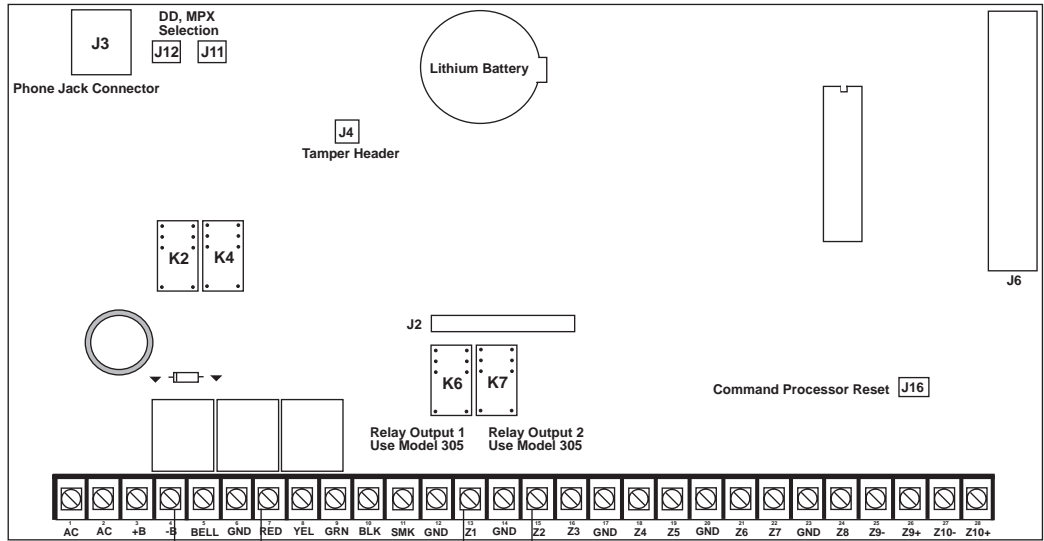

Dual Style D Initiating Module
Model 869

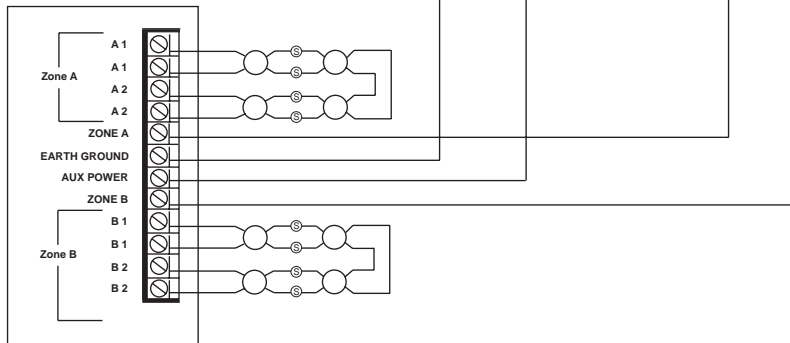

12 VDC Supply
25mA Standby Current
75mA Alarm Current

Heat detectors, manual pull stations, or any other UL listed shorting device.
Unlimited number of units.

34.4 Remote Station reversing relay connection

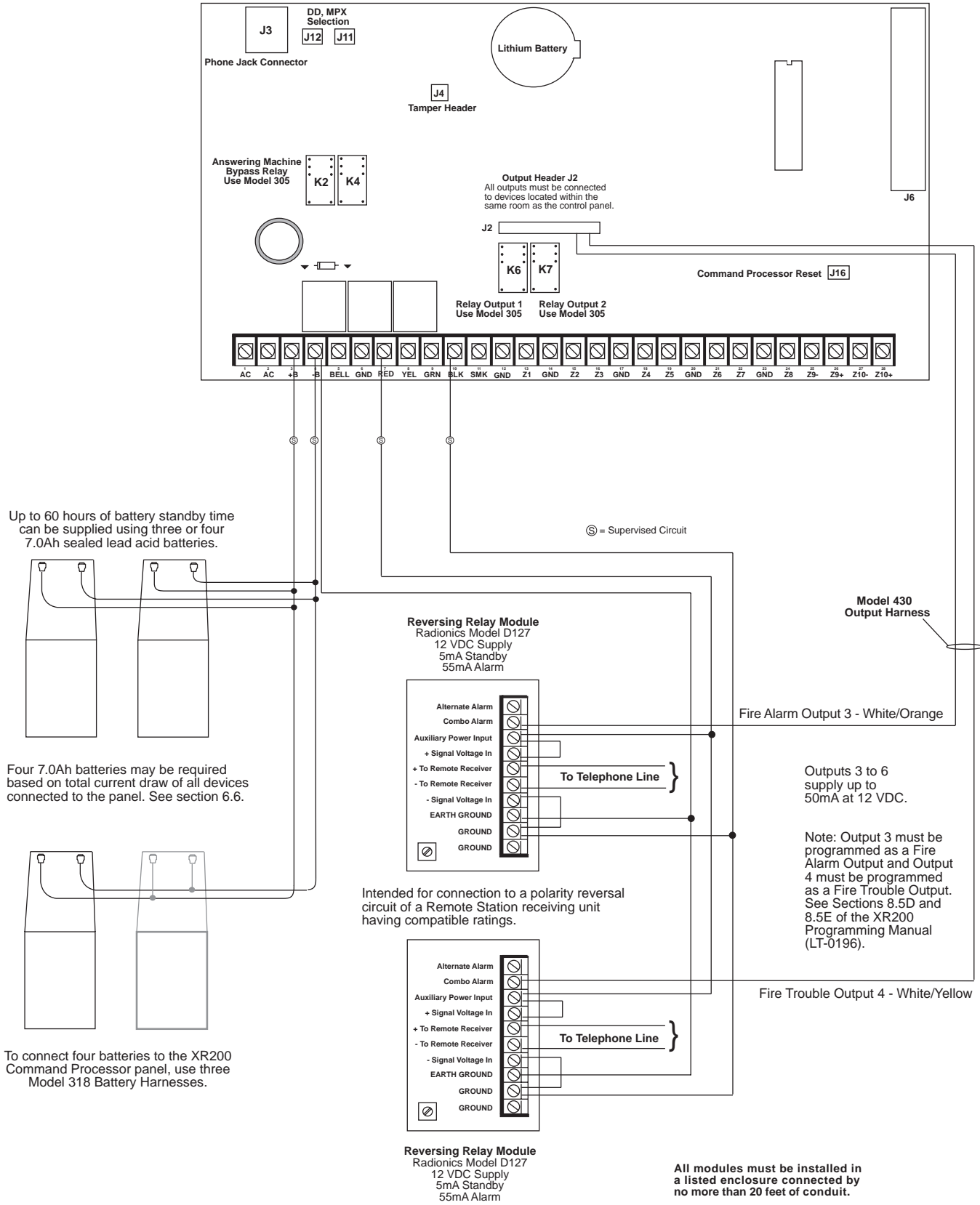

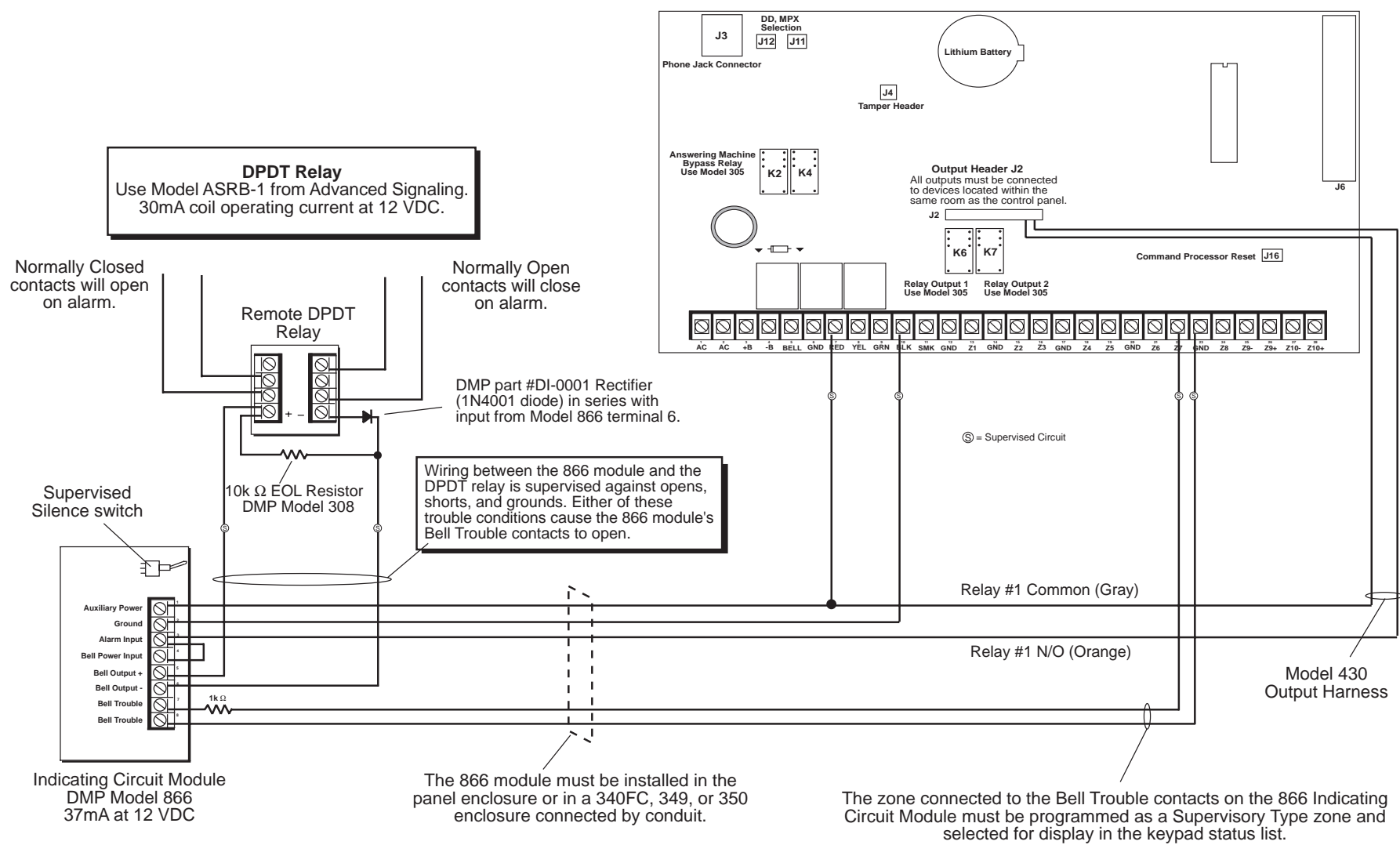

34.6 Cellular backup installation for Derived Channel burglary

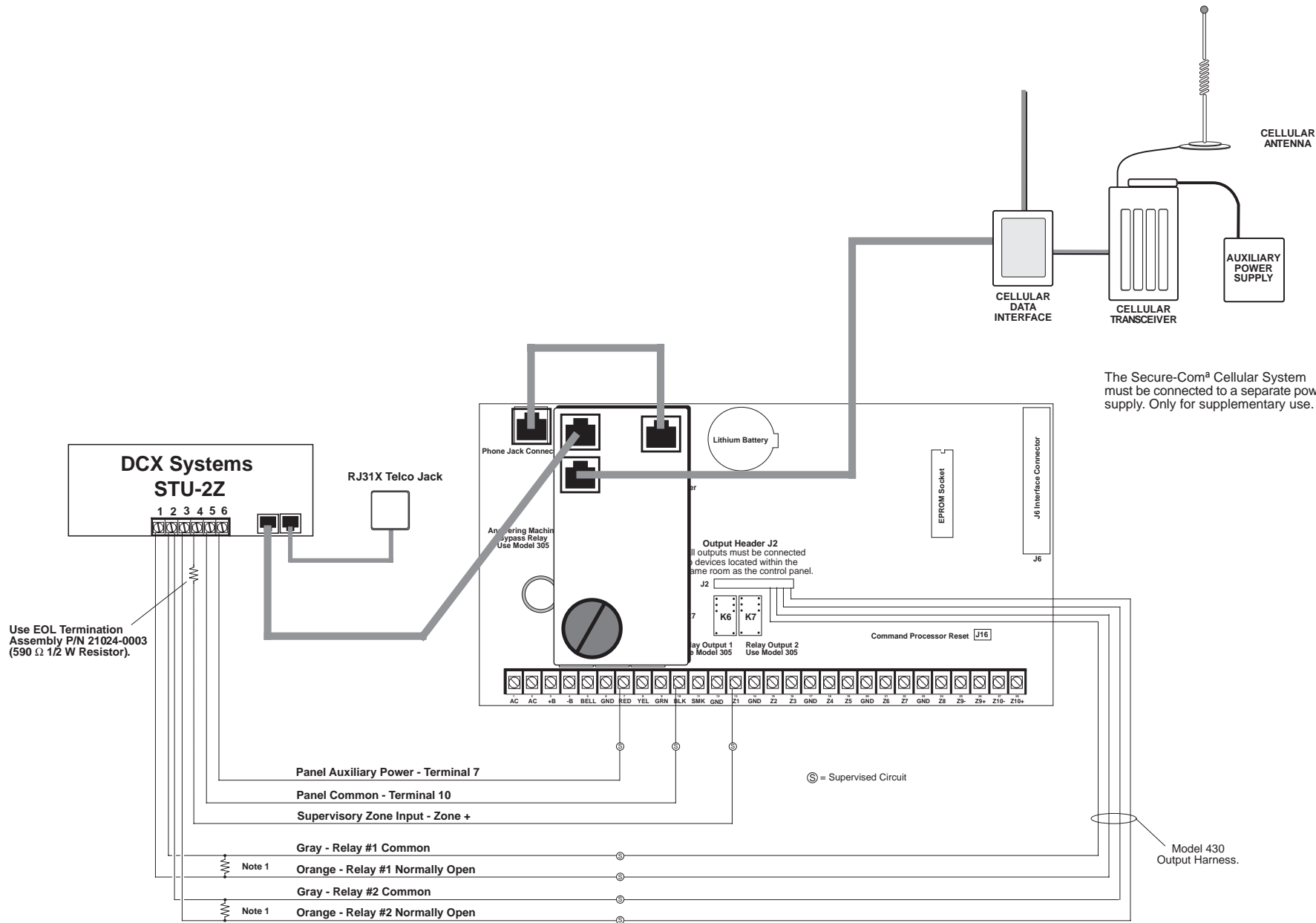

The Secure-Com[®] Cellular System must be connected to a separate power supply. Only for supplementary use.

Use EOL Termination Assembly P/N 21024-0003 (590 Ω 1/2 W Resistor).

- Panel Auxiliary Power - Terminal 7
- Panel Common - Terminal 10
- Supervisory Zone Input - Zone +
- Gray - Relay #1 Common
- Orange - Relay #1 Normally Open
- Gray - Relay #2 Common
- Orange - Relay #2 Normally Open

Note 1: Use EOL Termination Assembly P/N 21024-0001 (2.2k 1/2 W Resistor).

34.7 LX-Bus™ Module Connection

LX-Bus Expansion Card
DMP Models 462N, 462P, 472, or 481.

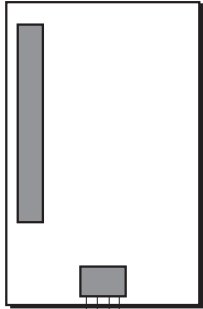

Each LX-Bus module must be selected with its own independent address from 00 to 99. A Supervisory zone must be programmed into the XR2400F to properly supervise each module.

Notification Circuit Module
DMP Model 867

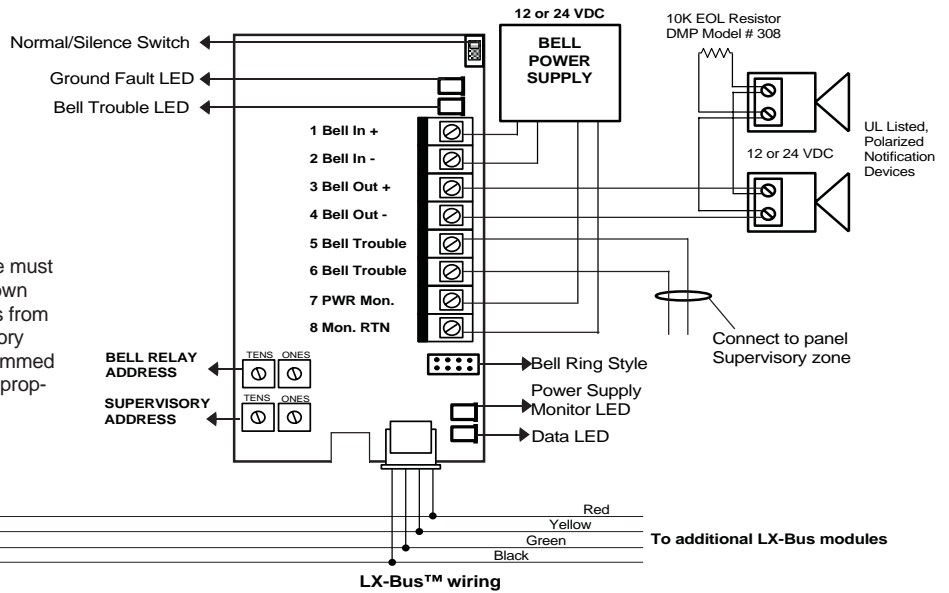

(S) = Supervised Circuit

Open Collector Annunciator Outputs

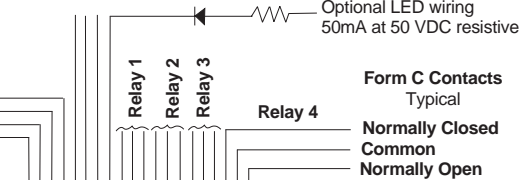

Output Expander Module
DMP Model 716
7mA at 12 VDC

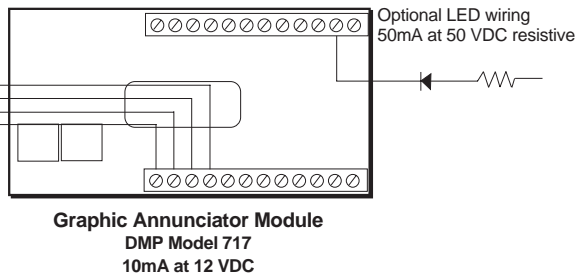

Graphic Annunciator Module
DMP Model 717
10mA at 12 VDC

34.8 Second LX-Bus with Auxiliary Power Supply

You can have up to twenty-five 866 Indicating Circuit Modules by using the relay outputs available on the XR2400F panel.

All modules must be installed within a 340FC, 349, or 350 enclosure connected by no more than 20 feet of conduit.

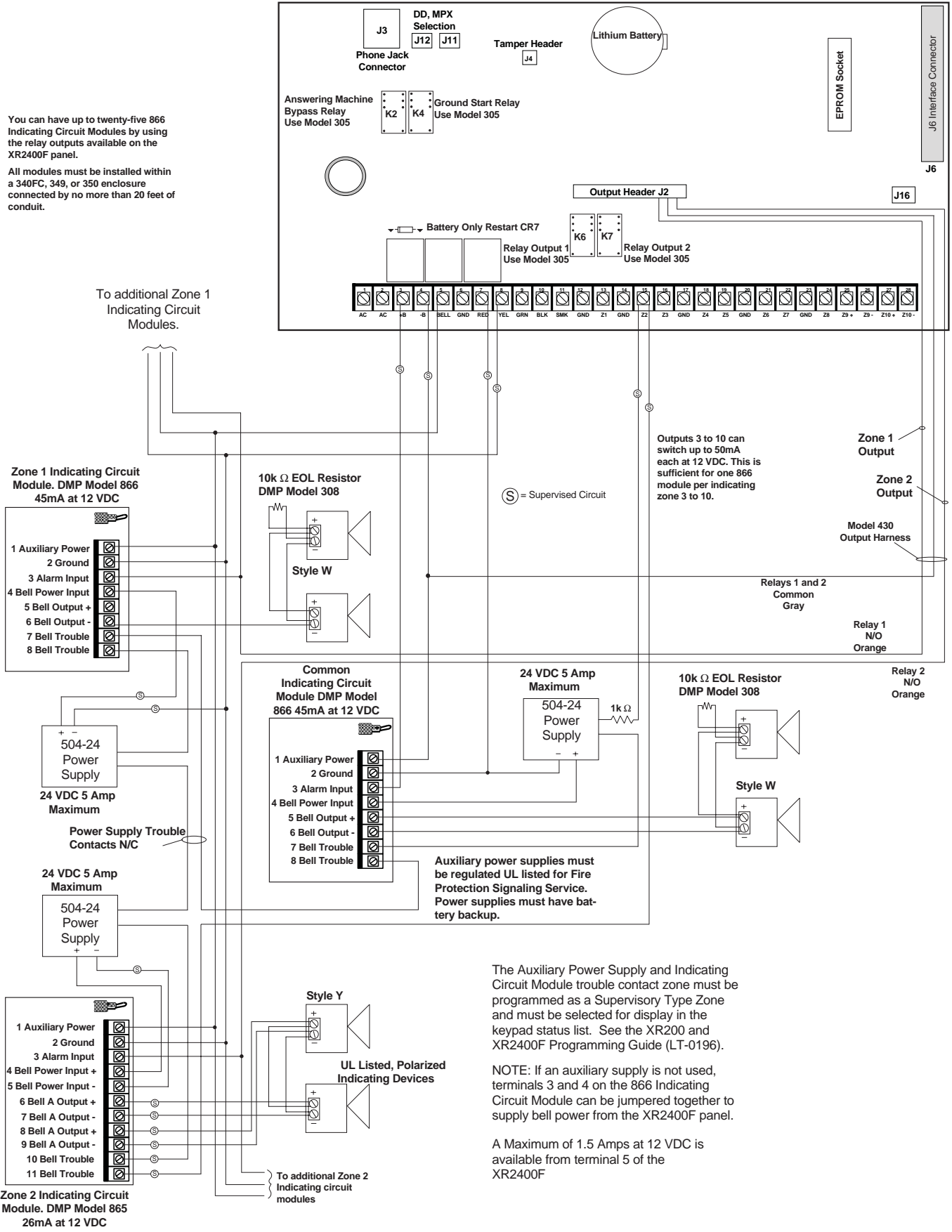

The Auxiliary Power Supply and Indicating Circuit Module trouble contact zone must be programmed as a Supervisory Type Zone and must be selected for display in the keypad status list. See the XR200 and XR2400F Programming Guide (LT-0196).

NOTE: If an auxiliary supply is not used, terminals 3 and 4 on the 866 Indicating Circuit Module can be jumpered together to supply bell power from the XR2400F panel.

A Maximum of 1.5 Amps at 12 VDC is available from terminal 5 of the XR2400F

OPERATING INSTRUCTIONS

XR2400F Addressable Fire Alarm Control Panel

NORMAL STANDBY CONDITION

When the system is in the normal standby condition, the display shows either the time of day or a blank display.

ALARM CONDITION

When the system is in an alarm condition, the display shows the alarmed zone name(s) followed by an alarm display.

KEYSWITCH OPERATION

In order to use the four function keys, the keyswitch must be turned to the enable position.

ALARM SILENCE

To silence the alarm while the bell or siren is sounding, press the key labeled "Silence" or enter your code number and press the COMMAND key. This silences the alarm but does *not* cancel any alarm reports to the central station.

RESETTING DETECTORS

To reset a smoke or other detector, press the key labeled "Reset" or enter the User Menu by pressing the COMMAND key until **MENU? NO YES** appears in the display. Press the top row key under **YES**. The display shows **ENTER CODE: - .** Enter your code number and press COMMAND. The display now shows **ALARM SILENCE?** Press the COMMAND key until **SENSOR RESET?** appears in the display. Press any top row key.

TROUBLE CONDITION

When a device is in a trouble condition, the keyboard tones and displays the zone or device name followed by **TRBL**. Press any top row key to silence.

SYSTEM TESTING

You should test the security system periodically to ensure proper operation. You can do this by pressing the key labeled "Test" or through a function in the User Menu. After entering the User Menu, press the COMMAND key until **SYSTEM TEST?** displays. Press any top row key. The system bell, battery, and communication to the central station system is then tested.

ALARM SERVICE

If service is required for this system, please contact:

Company _____

Address _____

Telephone _____

The operating instructions above should be attached to the front, or framed and located adjacent to, the Fire Alarm Control Panel or a Remote Fire Command Center.

Digital Monitoring Products

2500 N. Partnership Boulevard Springfield, MO 65803 800-641-4282